

Classroom to Mobile Robots Competition Arena: An Experience on Artificial Intelligence Teaching*

J. CARPIO CAÑADA,¹ T. J. MATEO SANGUINO,² S. ALCOECER,^{1,2} A. BORREGO,^{1,2} A. ISIDRO,^{1,2}
A. PALANCO^{1,2} and J. M. RODRÍGUEZ^{1,2}

¹Dpto. de Tec. de la Información, Sistemas Informáticos y Automática, Universidad de Huelva, Ctra. Huelva-La Rábida s/n, 21819 Palos de la Frontera (Huelva), Spain. E-mail: jose.carpio@dti.uhu.es

²Dpto. de Ing. Electrónica, Sistemas Informáticos y Automática, Universidad de Huelva, Ctra. Huelva-La Rábida s/n, 21819 Palos de la Frontera (Huelva), Spain.

This paper presents an educational experience developed in the fourth year of Computer Engineering degree at Huelva University (Spain). To make Artificial Intelligent (AI) learning processes more captivating, a new educational project was incorporated into classical teaching of Artificial Intelligence and Knowledge Engineering subject. In this paper, we present the experience fulfilled with a group of college students. Here it is related how they changed for some days their classroom lessons for the robotic competition arena. With this project we have extended regular classroom lessons with additional work that could be useful and cannot be provided by traditional practical lessons, the real life experience. As a real example about how the work was accomplished we describe the mechanical construction of the mobile robots as well as the software development process.

Keywords: artificial intelligence; engineering education; gaming; robotic competition

1. Introduction

This project was a perfect example to make students gain some interest in robotics, and robotic competitions are a good framework to develop classroom experiences. Competitions also offer the students the opportunity of meeting more experienced people on this field. It also helps students to realize that frequently, real life is different from the problems the students solve at the university. It is completely different to design or program code for a computer simulation and to do it for a real mobile robot.

For example, there are many factors that have to be taken into consideration, like the mobile robot's battery charge or the light at the competition hall. In our case, it gave us some valuable pieces of advice; some of them about hardware design and others about how to design our software.

The competition game consisted in developing a mobile robot able to follow a line as fast as possible in a simple track. But, which is the meaning of these terms?

- 'A robot is a virtual or mechanical agent. In practice, it is usually an electromechanical system which, by its appearance or motion, conveys a sense realized on its own'.
- 'A robotic competition is an event where robots have to accomplish a given task'.

These two definitions—given by Wikipedia—describe the concepts of a robotic competition. A robotic contest is important for AI because two robots with no human help or guidance have to

fulfill a given task faster or better than the rest of the competitors. In general terms, in a basic AI lab practice, it is enough if the robot accomplishes the task; no matter how long it takes to do it. In a robotic competition it is not enough; the behavior of the robots must also be changed and improved so it can beat the rest of the competitors.

There are many already developed robotic platforms as Pololu, e-puck [1] or Khepera [2] but we have developed the complete platform and control software for this hardware. So, students have developed new skills designing and building Printed Circuit Boards (PCBs), working with electronic components or designing embedded software. Almost all the technical teaching have the goal to form tomorrow's engineers and this experience brings class closer to real-life frameworks. For example, in Zhongli et al. [3] it is presented an Internet-based platform for a soccer competition devoted to robotics education. To facilitate the students' learning when participating in the robotics competition, the supporting hardware and software kits have also been developed. DeVault [4] describes an engineering experience through the implementation of a mobile robotics course and the participation in an annual robot contest. In Grimes et al. [5] the educational outcomes are described and student know-how to make of a competition an excellent opportunity for educational growth. In this paper is illustrated how the students have full responsibility for defining the competition rules, designing, constructing the course and carrying out the competition. In Berlier et al. [6] it is presented a meth-

Table 1. main features of some educational experiences on robotic competitions

Reference	Education Level	Kind of Competition	Programming Language	Field
[3]	Secondary	Robot soccer	Icon-based instructions	Robotics
[4]	University	Sumo wrestling	C	Engineering Physics
[5]	University	Ping-pong balls	C	Mechanical & Computer Engineering
[6]	University	Line following, maze-navigation & drawing	Assembly & C	Micro-computers
[7]	University	Robot soccer	C++	Robotics & Computer Vision
[8]	University & High School	Chessboard & robot soccer	GrafCet	Engineering & Computer Science
Onubot	University	Line following	Java	Artificial Intelligent

odology used to replace the final project with a robotics project where students build a microcontroller-based robot with the ultimate goal of competing. Murphy [7] describes a strategy for integrating robot design competitions into courses in order to maximize learning experience and promote intellectual development. Finally, in Almeida et al. [8] mobile robot competitions are presented as events well suited to experimentation, research and development in many areas concerning both High School and University.

The present paper is organized in the following way. The ‘General Overview’ section presents the ‘OnuBot’ teamwork and how the motivation to compete comes from the classroom to mobile robots competition arena. The following section ‘Project Development’ explains the task development and how the work was accomplished. The ‘Competition’ section briefly discusses the results of this game. The ‘Experience in Teaching’ section puts into practice the methodology developed by this teamwork so far, an evaluation questionnaire is presented with such purpose. Finally, this paper contributes with some conclusions to the work carried out; it provides new expectations and offers this experience to the engineering community at its social website.

In order to highlight the contributions of this teaching innovation project, different features and properties are compared to some of the aforementioned educational experiences (see Table 1).

2. General overview

We have used mobile robots during the last five years as a means of teaching main mobile agents aspects. In the first years students showed an excellent motivation. Nevertheless, this interest gradually decreased in the following years. These students were doing the fourth year of ‘Computer Engineering’ degree at Huelva University and this project was developed in the ‘Artificial Intelligence and Knowledge Engineering’ subject.

The experience started in the academic course 2008/2009 and was mostly carried out by students. This experience allowed us to obtain a teaching innovation project awarded by the University of Huelva. This project let the teachers set up two different students’ teams and two different mobile agents—Mini-Z and Iwaver 01—with the goal of participating in a national robotic competition called ‘Cosmobot 2009’ (see Fig. 1). The competition was held by 24 teams from different national universities. The game consisted of developing two mobile robots able to follow a line as fast as possible in a simple closed track.

This collaborative experience is not only understood as a serial of practical sessions. Otherwise it comprises the possibility of discovering AI techniques with the aim of a robotic competition. In this project we have extended regular classroom lessons with additional work that would be useful and may not be provided by many traditional practical lessons. Such tasks—approximately 600 hours—consisted in working with electronic components, develop PCBs, designing embedded software, modelling the systems by using Unified Model Language (UML) diagrams or testing AI algorithms (see



Fig. 1. The Onubot teamwork in the competition arena during Cosmobot.

Table 2. List of tasks and hours spent on the project

Item	Hours	Persons	Task
1	2	7	Briefing & work organization
2	3	6	Working with robot: task planning, interfaces, programming & debugging
3	3.5	3	Working with robot: track design & reactive algorithm
4	4.5	5	Schematic & layout design with Eagle
5	4	1	Mapping & testing track algorithm
6	3	6	Printing board, develop & etching
7	4.5	2	Reactive algorithm & adjust parameters
8	3	2	Welding, drilling & assembling PCB
9	2	3	Reactive algorithm & optimization for straight lines
10	2	1	Working with robot: testing algorithm in circuit with predominance of curves
11	5	2	Testing with robot: creation of new circuits & parameter settings
12	6	1	Working with 2nd robot: assembly, testing & new servomotors
13	2	2	Research on CMUcam
14	5	4	UML design: tasks & processes to perform
15	3	1	UML specification: classes, attributes & methods
16	9	7	Code debugging and circuit preparation
17	12	4	Improving code
18	3	3	Algorithm advances with Iwaver & Mini-Z robotic vehicles
18	40	7	Cosmobot 2009 competition
20	10	2	Updating webpage
21	6.5	1	Microcontroller research
22	4.5	1	Documentation of the directed academic work

Table 2). So, working in group has also been important to accomplish the project.

3. Project development

3.1 Rules of the competition

The first task we had to do, once the working team had been formed, was to study the rules of the competition which had been previously published at the ‘Cosmobot 2009’ official website. This information included all the requirements to be fulfilled by the participants and their robots. To sum up, the most relevant aspects were the following:

- Every team should be formed by four members with one representative.
- Every team could have more than one mobile robot.
- The track was closed, white and delimited in both sides by black insulating tape lines of 2 cm wide. The whole track was 1550 cm wide. At the same time, there was a margin of 15 cm in each side delimited by a red insulating tape.
- The mobile robot should not ever reach those lines in its routes because it would be disqualified.
- The bends were made of pieces of circumference whose radius was always over 40 cm.

In addition, there were some possible eventualities contemplated as, for example, the fact that the track had little irregularities or that the lighting condition was not defined beforehand. Finally, it is important to point out the limitations imposed on the vehicles. They must have a maximum dimension of 20 cm wide \times 30 cm long \times 13 cm high, apart from being completely autonomous. It was comple-

tely forbidden the existence of any remote control element.

3.2 Brainstorm meetings

Once all the rules of the competition were known, we met in order to prepare the work to develop. On the one hand, the leader suggested the teamwork the strategy of buying two specific mobile robots which had a reduced size and low cost. On the other hand, we had to make our own PCBs where we had to insert the chosen microcontroller, sensors and other electronic devices. Once the PCBs had been made it would be joined to the chassis of the vehicles and the appropriate connections would be done.

The robotic vehicles—Mini-z and Iwaver 01—both had very similar qualities and their dimensions where approximately 12 cm long \times 7 cm wide \times 4 cm high (see Fig. 2). The chosen microcontroller was

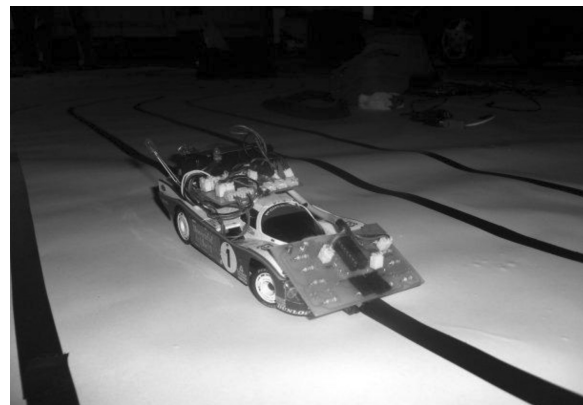

Fig. 2. Iwaver 01 robot of the Onubot teamwork in the competition arena during Cosmobot.

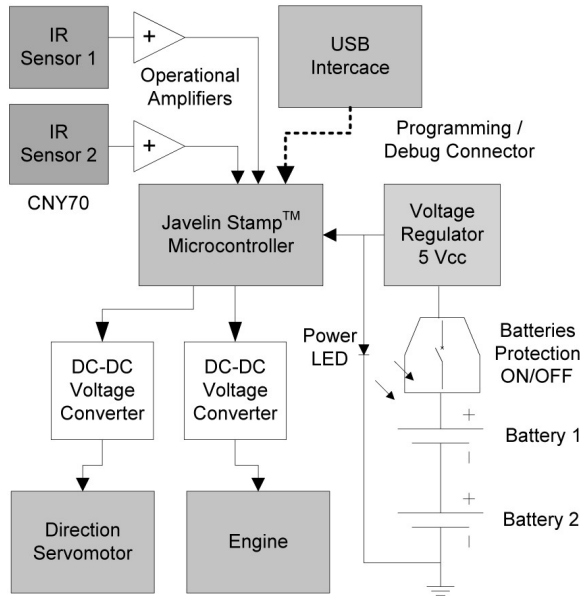

Fig. 3. Outline of the electronic aboard the robotic vehicles.

Javelin Stamp™ from Parallax enterprise (see Fig. 3). This election was due to the fact that we were already familiar with the use of this microcontroller in the practices of ‘Artificial Intelligence and Knowledge Engineering’ subject. In these practices we got in touch with the robots programming and with external elements interaction. During the first meeting of the teamwork we considered the possibility of using the Parallax version of CMUcam camera as a complement of the car. The rules allowed it and at the beginning, we thought that it would be useful to give a computer feedback vision to the vehicle. We guessed that the robotic vehicles could see the bend before arriving and react with more efficiency. Finally, this option was ruled out because of several reasons. First, the camera’s weight decreased the speed and stability of the vehicle as well as its autonomy. Second, the processing capacity required by this camera and the microcontroller became inadequate.

Inspired by the mobile robots used in our practices, we decided to include two sensors in the central part at the front of the vehicle. We also established that the vehicle would go over the line, although it was allowed to cover the white track space. We left the possibility to add two extra sensors, one in each extreme of the front side.

3.3 PCB layout and assembling process

Once the working process became clear, we started to meet again during the following days, this time in order to make the PCB design by means of EAGLE Layout Editor®. The electronic circuit was already designed so we printed it in transparencies. Taking advantages of the University’s facilities we could use

a laboratory to make the PCBs. The process had the following steps:

- Designing and cutting the light photosensitive bakelite with the intended size.
- Sticking tightly, by means of sticky tape, the piece of the PCB and the printed sheet. After this, putting them into the isolation machine. This machine is like a photocopier with a special light and, in fact, it carries out a similar function applying an ultraviolet light to the whole PCB. The light intensity excites the PCB’s surfaces except the drawn mask that will be the copper traces of the future circuit.
- When it became photosensitive, the board was carefully introduced into a photo-sensitive dissolution of a specific product to reveal it.
- Etching all the photosensitive PCB area leaving only the fiberglass base with the printed circuit intact.

The assembly of the hardware was the following task. Once we already had the PCBs, we only had to drill, sold and assemble the set of resistances, capacitors and undoubtedly the microcontroller.

3.4 Software specification and requirements

Due to the short time available to build and program the robots, it was necessary to distribute the different task between the people in the project, so we could finish on time. To achieve this goal we modelled the system using UML diagrams.

We decided to clarify the way to develop the desired work in a common and efficient way. In that sense, we had to carry out a detailed analysis of all the existing variables related to the competition. Accordingly, the variables were classified taking into account if they were related to the robotic vehicle or the track. These variables are shown in Table 3. It can be observed that light intensity affects the measurement of the sensors. On the other hand, when the battery charge got low, the speed and acceleration got down. Regarding the speed, we had to decide if put the cars at high speed or medium speed. With high speed, the cars sometimes went off

Table 3. Classification of variables related to the mobile robots and the track of the competition arena

Variables	Related with
Light intensity	Sensor measurements
Battery charge	Speed & acceleration
Maximum speed	Risk level
Turning angle	Motion in a curve or in a straight line
Number of sensors	Accuracy
Physical limits	Behavior of the robotic vehicle
Stretches position	Anticipation to the next event
Friction	Behavior of the robotic vehicle
Pothole	Disorientation

the road so we had to decide what level of risk we should accept. It was also important to know if the cars were in a curve or in a straight line because the turning angle to correct the car should be different. Taking into account our experience, the number of sensors was an important lack of our robotic vehicles since they only had two sensors. We discovered that it could not have enough accuracy; nevertheless, it was enough for our design. It was also very important to know other physical limitations like size of the wheels, position of axis direction, weight, stability and specially the hit resistance. According to the variables related to the track of the competition arena, stretches position may be the most important variable. We programmed the car with a map of the circuit so it could always be in the best position and anticipate the next event before it came. With this, we hoped the car braked before the curve and accelerated when the straight line was beginning. With relation to friction, it was important to know that the results obtained in our tests could differ significantly from the results obtained in the official circuit due to material construction. Another quite important aspect was the pothole. Both our test circuits and the official one contained undulations. These strains were mainly caused by the tension of the tape that formed the path. Our small robotic cars were negatively influenced by it.

We concluded that if we knew the features of the track, we could set a clear analysis and the mobile robot could react before. By means of that, we could do diagrams about the program structure in UML format. Besides, it would be necessary to program every section of the track in a single way, so that we could finally combine all of them. Thus, we realized that students required an additional effort to provide a high reliability to the design of mobile agents. Usually this aspect is not crucial for general purpose software developed on AI. That is, when something wrong happens the computer engineer usually shows 'windows alerts'. On the contrary, in a competition a fault means the end of the game for competitors; no faults or errors are allowed. Indeed, this aspect is difficult to learn outside of a real problem.

3.5 Firsts tests at the laboratory

The program was developed in Java language but avoiding the use of classes and minimizing the calls to external functions to reduce the computational cost (see Fig. 4). We realized that we based our strategy in a good software design, but our basic hardware did not let us make a working program that could satisfy the competition requirements. It was difficult to fulfill the task with our designed hardware because we designed a simple and fast system with only two light sensors with digital signal

processing. When we tried to make a high speed control with only two sensors, we comprehended that environmental light conditions and circuit surface would cause wrong measurements. Thus, at high speeds these fails cause the mobile robots loose the line and go out from the circuit. Consequently, the team would be withdrawn from the competition.

In the following stage, we thought it would be a good idea to make a copy of the competition track, so we started working on that. One of the problems consisted on the material to support the track; getting a plastic sheet was too expensive. As a consequence, we used a great toll of paper as the base. To do this, we firstly added several sheets in order to get the desired dimensions. Secondly, by means of a tape, we composed the straight lines and the curves all the way long. We already had our track; thanks to it we could perform our first reliable test.

```

// */
public static void wait_start(){
    System.out.println("pass1");
    while(CPU.readPin(SWICTH) != ON){
        System.out.println("pass2");
    }
    while(CPU.readPin(SWICTH) == ON){
        System.out.println("pass3");
    }
}

public static void main (){

    int MAXIMUM_TURN = GREAT_TURN[2];
    int MINIMUM_TURN = LITTLE_TURN[0];
    int MAXIMUM_SPEED = HIGH_SPEED[1];
    int MINIMUM_SPEED = LOW_SPEED[1];
    int direction=1; //1 right, -1 left
    int speed = MINIMUM_SPEED;
    int turn = 0;

    // wait_start();

    CPU.writePin(LED1,true);
    CPU.writePin(LED2,true);
    while(true){
        servo_mot.update(neutral_engine+speed, low_mot);
        servo_dir.update(neutral_direction + (turn * direction), low_dir);

        if (CPU.readPin(SID) == INSIDE && CPU.readPin(SDD) ==
        INSIDE){
            speed = HIGH_SPEED;
            turn = 0;

        }else if(CPU.readPin(SID) == INSIDE && CPU.readPin(SDD) ==
        OUTSIDE){
            turn = MINIMUM_TURN;
            direction = 1;

        }else if(CPU.readPin(SID) == OUTSIDE && CPU.readPin(SDD)
        == INSIDE){
            turn = MINIMUM_TURN;
            direction = -1;

        }else if(CPU.readPin(SID) == OUTSIDE && CPU.readPin(SDD)
        == OUTSIDE){
            turn = MAXIMUM_TURN;
            speed = MINIMUM_SPEED;
        }
    }
}
}

```

Fig. 4. Example of code implemented in the mobile robots.

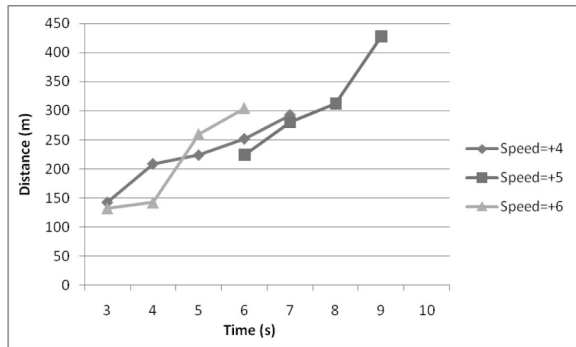

Fig. 5. Speed variations with different AI algorithms applied to the vehicles.

At that moment we could see the true necessity to improve the speed and the efficiency of the robotic vehicle. Moreover, we could face the problem of the distortions on the track beforehand. These were mainly caused by the tension produced, not only by the insulating tape but also by the paper fragility. This situation would be reflected on the true track. That is the reason why all participants had the same problems like us.

The software development continued but it did not live up to our expectation. We understood the necessity of having more sensors for a better accuracy measurement that would influence the behavior with more precision. In addition, we had difficulties with the batteries, so the battery overuse by the car's engines negatively influenced on acceleration and braking cycles. These and other reasons made us decide to load a more primitive algorithm into the robot only few days before the competition. This algorithm did not perform complicated intelligent analysis; it simply read the sensors, being the engine speeds and servomotors' direction constant. The result was not very fast but at least it did not come off the bends and allowed a higher working autonomy. In Fig. 5 it can be seen these tests realized with algorithms tuned at different speeds. The lines show distance travelled by the robotic vehicle (expressed in cm) versus time (represented in seconds).

4. Competition

We went to 'Cosmobot 2009' with the proof material including our track. We were surprised due to the fact that any participant did not carry anything similar and they only had little stretches over different surfaces to calibrate the sensors' sensibility. This made us reflect upon the greater importance of pure mechanics and electronics versus the computer analysis we mainly had done. All competitors tried out their vehicles in our track and we apprehended the invested effort had been worthy: most vehicles came off or made maneuvers that would make them

fail. We could notice some similar models of robotic vehicles like our ones with very specialized features prepared for this competition. As we could check later these competitors kept on participating with all their vehicles.

The competition took place in a very short time and in a very good sporting atmosphere. Its dynamics was also specified in the rules. It would consist of a first validation lap in which all the robot vehicles had to prove their capacity to cover the track without coming off the time limit. Later, each vehicle performed individually a round of three tries. The goal was to complete at least two laps in the shortest possible time. Once all the vehicles attained the classification, approximately half of them went to the following step: the car chase. In this step, two vehicles placed in opposite points of the track started at the same time. The race finished when one of the two mobile robots reached the other and the winner was the one which had done it twice in at least two big tries.

We did not have any problem at passing the validation lap and the classification later but the quality of our opponents exceeded our robotic systems. Our teams took 41.87s to make 2 laps with an average speed of 0.54 m/s. The best competitor took 14.93 s to make the same laps with an average speed of 1.52 m/s, taking 102.60 s the worst runner with an average speed of 0.22 m/s. This made us finish in a middle position. When the competition finished the winners were congratulated and agreed to be interviewed by us. It was very interesting to share experiences with different competitors who kindly explained the bases of their designs. The experience has been quite pleasant and we consider that in this first attempt we have learnt a lot of things about working in group, especially when this work is orientated towards a competition task.

5. Experience in teaching

With the aim of addressing innovative teaching and learning methods related to this experience, we have evaluated the students' opinion and their implications for Engineering Education. A statistical study has been carried out on two teamworks of students and teachers during 2009 (see Table 4) with a score ranging between 1 (completely disagree) and 5 (completely agree). The questionnaire includes aspects referred to how the educational gaming has improved teaching-learning practices in university education. Two groups of users (6 students and 2 professionals) have been considered.

Questions 1 to 11 describe the level of knowledge acquired on several technical fields like electronics, sensors and microcontrollers as well as transverse knowledge like project management, software pro-

Table 4. Evaluation questionnaire of the experience in teaching

Question	Description	Teachers	Students	Deviation
1	Acquired knowledge on electronic	3	4.25	0.76
2	Acquired knowledge on project management	3.5	3.25	0.76
3	Acquired knowledge on software programming	3	3.5	0.28
4	Acquired knowledge on modelling system	4	4	0
5	Acquired knowledge on designing system	3.5	4.25	0.5
6	Acquired knowledge on developing system	3	4.25	0.76
7	Acquired knowledge on sensors and actuators	4	4	1.25
8	Acquired knowledge on computer languages	3	2.75	0.76
9	Acquired knowledge on microcontrollers	3.5	3.5	0.5
10	Acquired knowledge on 'Artificial Intelligent' subject	3	3.75	0.5
11	Acquired knowledge on testing phase	4	3.75	0.28
12	Acquired knowledge on working competition	4.5	4.5	0
13	Acquired knowledge on writing documentation	3	4	0.76
14	Acquired knowledge on working within a team	4.5	4	0.76
15	Project organization	3	4	0.76
16	Resources available	3	4.5	0
17	Similar known experiences	3	3.5	0.57
18	Other national robotic groups known	4.5	4	1.04
19	Motivation in the study of robotic agents	4	4.5	0.57
20	Motivation in the study of 'Artificial Intelligent' subject	4.5	4.5	0.5
21	Evaluation of the competition experience	4.5	4.5	0
22	Global evaluation of this teaching innovation project	4.5	4.5	0

gramming, and modelling, designing and developing of systems (see fig. 6a). In these items it can be observed that students' rates are higher with those questions related to hardware development (questions 1, 6 and 7) and lower with those ones related to software programming (questions 3, 6 and 8). The low rate in question 8 indicates that students already

have a thorough knowledge of programming languages when they get to fourth course in Computer Engineering. On the other hand, question 10 proves that AI knowledge has been strengthened.

Figure 6b shows how the students' opinion agrees with the opinion of teachers. Most of the questions favorably scored are related to the working competition and the social development of the person (question 12). Perhaps, the most important interpretation is that questions 19 and 20 stand out the motivation and its implications for both 'Artificial Intelligent' subject and robotic agents. In this sense, students and teachers highlight the success of the competition experience being rather high (questions 18, 21 and 22). It is still too early to obtain concluding results; although the developed analysis leads the professionals to conclude that with the educational experience we obtained several additional targets that helped students to develop their skills. In general terms, it has been a great learning experience, we have learned from the difficulties and even when the results were not the expected ones, all the acquired knowledge was perfectly worthy.

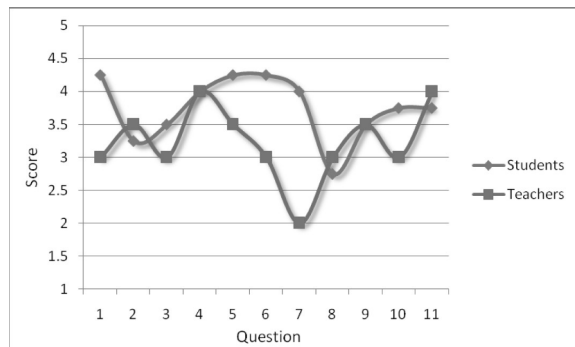

(a)

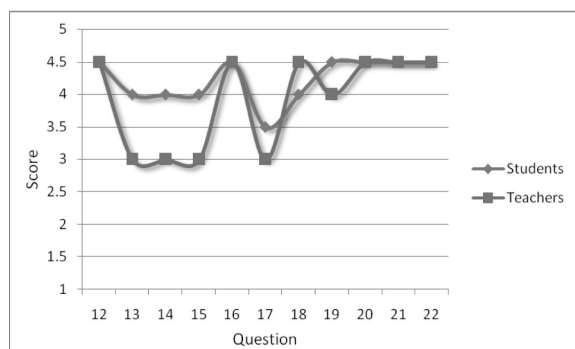

(b)

Fig. 6. Average score of students and teaching professionals.

6. Conclusions

Student motivation is an essential issue in a learning process and it implies a challenge for educators who want to preserve and increase this educational aspect. We have used mobile robots during the last five years as a means of teaching mainly mobile agents aspects. In the first years students showed excellent motivation. Nevertheless, this interest has gradually decreased in the subsequent years. In order to make more captivating the AI learning

process, we decided to incorporate a new practical session. That session comprises the possibility to share discovered AI techniques in a robotic competition. In this paper, we present the experience fulfilled with a group of students at university who changed for some days their classroom lessons for the robotic competition arena. We describe the mobile robots construction and software development process including modelling, design, and implementation and testing phases.

We conclude that participating in robotics competitions gives university students a broader vision of AI subject, extra motivation and the possibility to share knowledge with more experienced students belonging to other universities. In order to evaluate the teamwork's activities, we present a pedagogical survey that emphasizes the importance of working in group with a real robot designed for a competition. Our experience will always be a good start point to develop a similar project with future promotions. Furthermore, the positive experience has brought up so much expectatives that teachers and students have confirmed to compete this year again. Besides, the students evidence the intention to accomplish future works in AI mobile agents' domain. Videos, links and further information about this work are available at the Onubot teamwork's site: www.facebook.com/pages/Onubot/103904463217.

Acknowledgements—We are grateful to the Teaching Innovation Service of the University of Huelva that promoted this project

(PIE084/2009). We would also like to thank the Department of Electronic Engineering, Computer Systems and Automatics for providing its laboratory for manufacturing the PCBs.

References

1. F. Mondada, M. Bonani, X. Raemy, J. Pugh, C. Cianci, A. Klaptocz, S. Magnenat, J. Zufferey, D. Floreano, A. Martinoli and P. Gonçalves, The e-puck, a Robot Designed for Education in Engineering, *Proc. 9th Conference on Autonomous Robot Systems and Competitions*, **1**(1), 2009, pp. 59–65.
2. F. Mondada, E. Franzi and P. Ienne, Mobile robot miniaturization: A tool for investigation in control algorithms, *Proc. Third International Symposium on Simulation on Experimental Robotics (ISER-93)*, **200**, (1993) pp. 501–513.
3. Zhongli Wang; Yafang Liu; Dongxiao Wang; Qingyun Li; Tai Chen; Liu, Y. H.; Yunde Jia, Internet Based Robot Competition and Education, *IEEE International Conf. Robotics and Biomimetics (ROBIO 2007)*, (2007) pp. 285–290.
4. J. E. DeVault, A competition-motivated, interdisciplinary design experience, *Proc. Frontiers Educ. Conf. (1998 FIE)*, (1998) pp. 460–465.
5. J. Grimes and J. Seng, Robotics Competition: Providing Structure, Flexibility, and an Extensive Learning Experience, *38th ASEE/IEEE Frontiers in Education Conference*, (2008) pp. 1–5.
6. J. A. Berlier and J. M. McCollum, The robot competition: A recipe for success in undergraduate microcomputers courses, *IEEE International Conf. Microelectronic Systems Education (MSE '09)*, (2009) pp. 126–129.
7. R. R. Murphy, A Strategy for Integrating Robot Design Competitions into Courses in Order to Maximize Learning Experience and Promote Intellectual Development, *IEEE Robotics & Automation Magazine*, **8**(2), 2001, pp. 44–45.
8. L. Almeida, J. Azevedo, C. Cardeira, P. Costa, P. Fonseca, P. Lima, F. Ribeiro and V. Santos, Mobile Robot Competitions: Fostering Advances in Research, Development and Education in Robotics, *CONTROLO'2000 the 4th Portuguese Conf. Automatic Control*, (2000) pp. 592–597.

José Carpio Cañada is Computer Engineer. Since 2004, he has worked as a full-time Associate Teacher in the Department of Information Technology at the University of Huelva (Spain). His research lines are focused on robotics and artificial intelligence.

Tomás de J. Mateo Sanguino is Electronic Engineer, Master in University Teaching and Doctor. From 1998 to 2004, he was granted a scholarship at the National Institute of Aerospace Technology (INTA) and worked as a hired engineer at the Spanish National Research Council (CSIC). Since 2004, he has worked as a full-time Associate Teacher in the Department of Electronic Engineering, Computer Systems and Automatics at the University of Huelva (Spain). Besides, he currently works as an instructor in the CCNA program at the CISCO Networking Academy. His research lines are focused on robotics and engineering education.

S. Alcocer Vázquez, A. Borrego Delgado, A. Isidro de la Cruz, A. Palanco Salguero and J.M. Rodríguez González are students of Computer Engineering at University of Huelva (E.P.S. La Rábida).