



ISRS Project

WP1: Study of Beam Dynamics, Injection/Extraction Systems and Beam Diagnostics

Progress Report

Javier Resta-López
ICMUV, University of Valencia, Spain



ISRS Collaboration Meeting
19th June 2024



Financiado por
la Unión Europea
NextGenerationEU

Contributors

Team at the University of Valencia



Javier Resta López
(PI)



Jorge Giner Navarro
(Senior Researcher)



Yanis Fontenla Barba
(Research Associate)



Fazel Taft
(PhD student)



Juan Rodríguez Pérez
(PhD student)

Collaborators:

Ismael Martel and his team (UHU),
Teresa Kurtukian Nieto (IEM-CSIC),
Glyn Kirby, Volodymyr Rodin (CERN, CH),
Carsten Welsch (ULIV, UK)
and practically all members of the ISRS Collaboration

T1.3. Study of beam dynamics

T1.3.2. Selection of machine layouts and lattices

Different options and **previous designs**

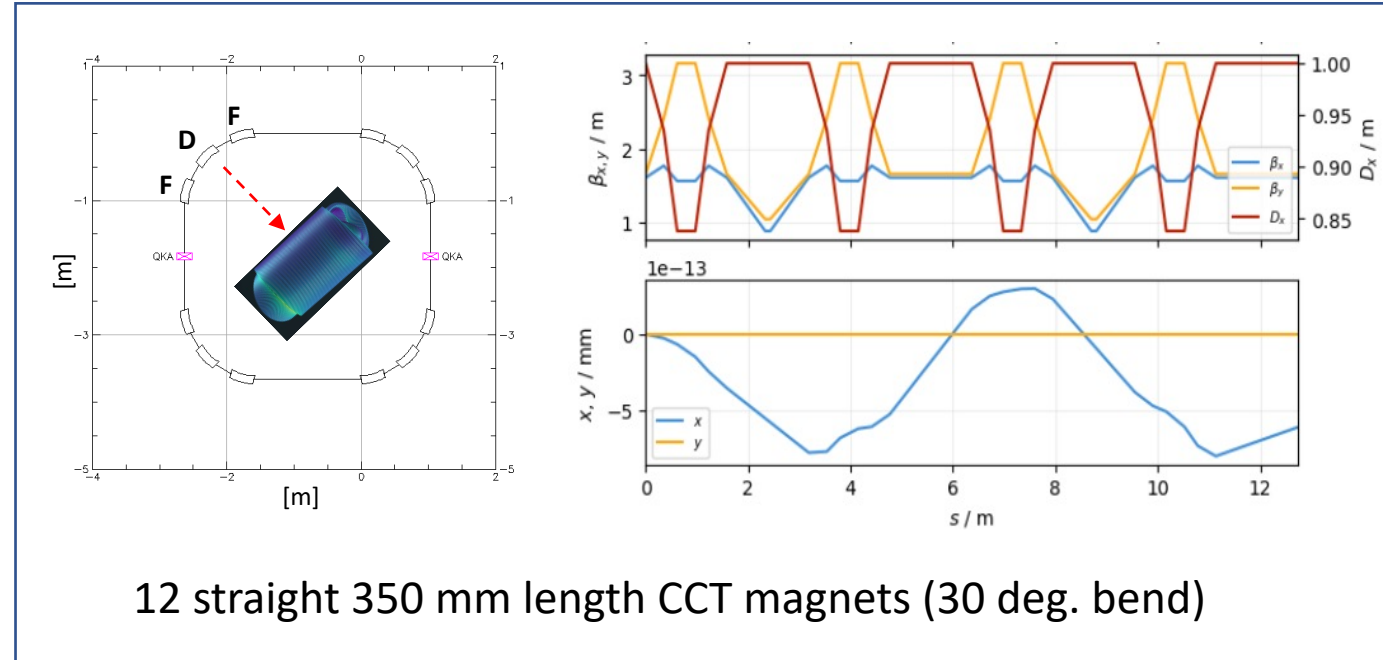
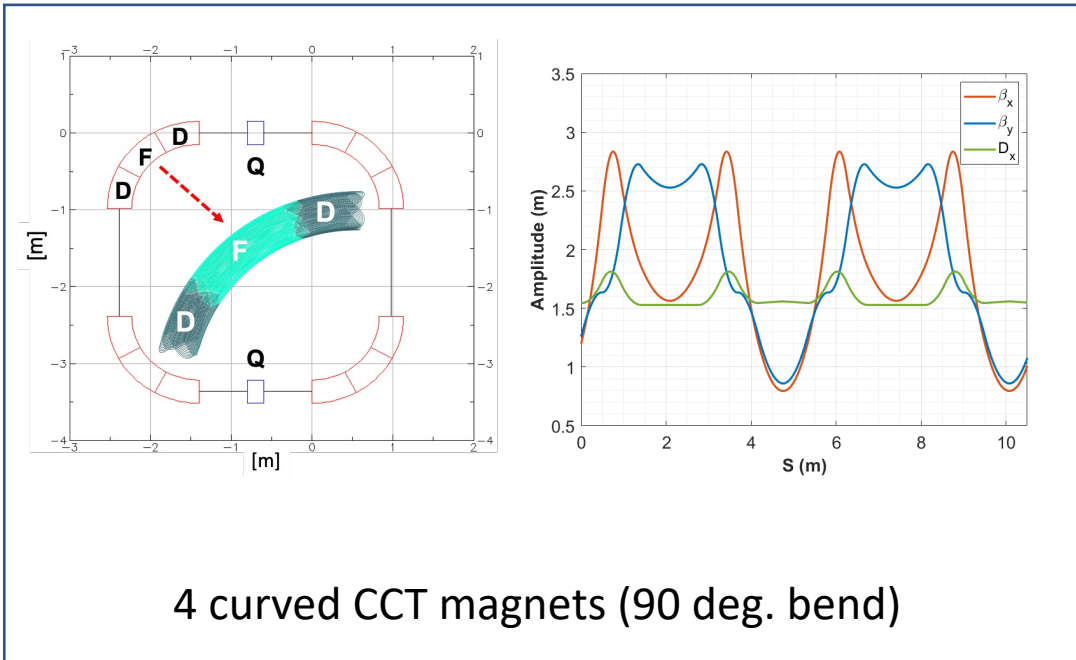

Magnet models (based on the software Rat GUI) revealed that the effective CCT magnetic length must be higher than 500 mm to safely operate the magnet in terms of thermo-mechanical parameters obtaining the required dipolar and quadrupolar strengths

T1.3. Study of beam dynamics

T1.3.2. Selection of machine layouts and lattices

Latest design based on 580 mm effective magnetic length CCT magnets

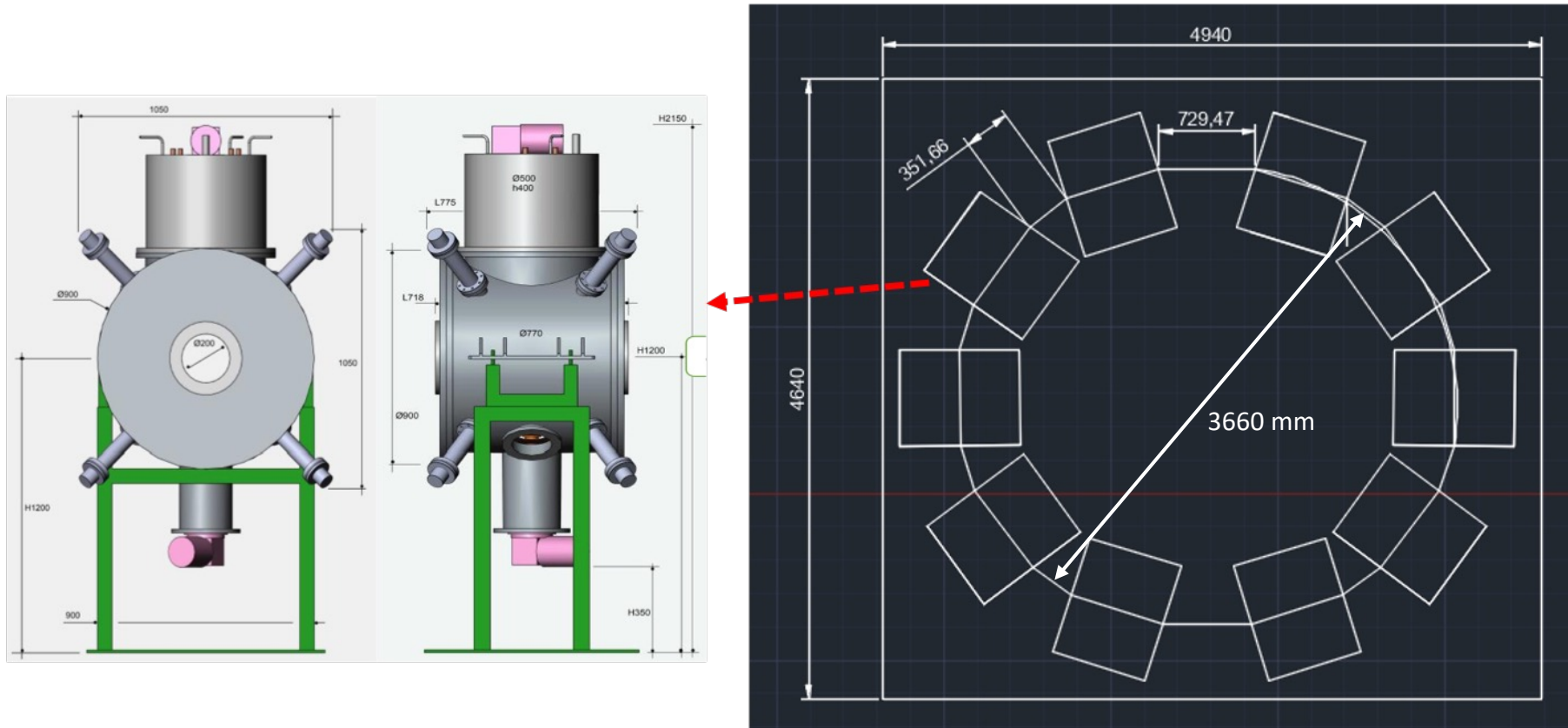

Layout considering the real size of the ensembled element

(units in mm)

T1.3. Study of beam dynamics

T1.3.2. Selection of machine layouts and lattices

Latest design based on 580 mm effective magnetic length CCT magnets

Optical layout using the code BMAD

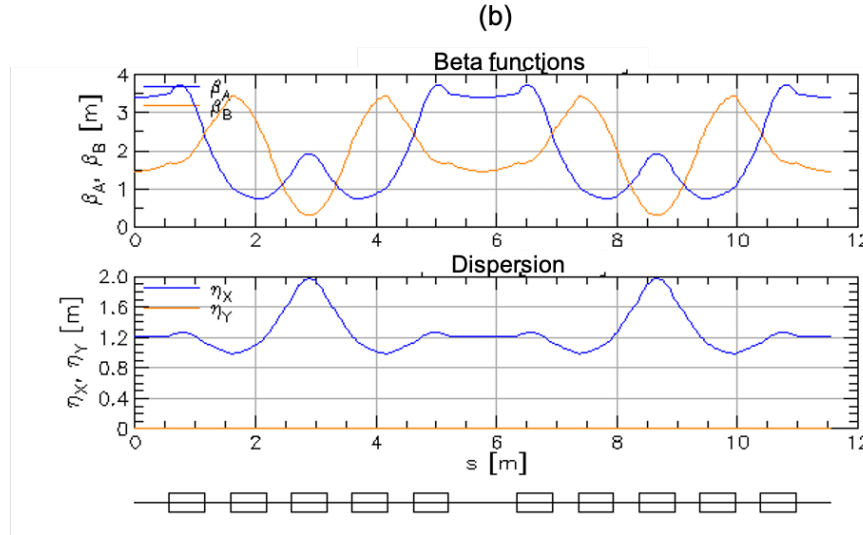
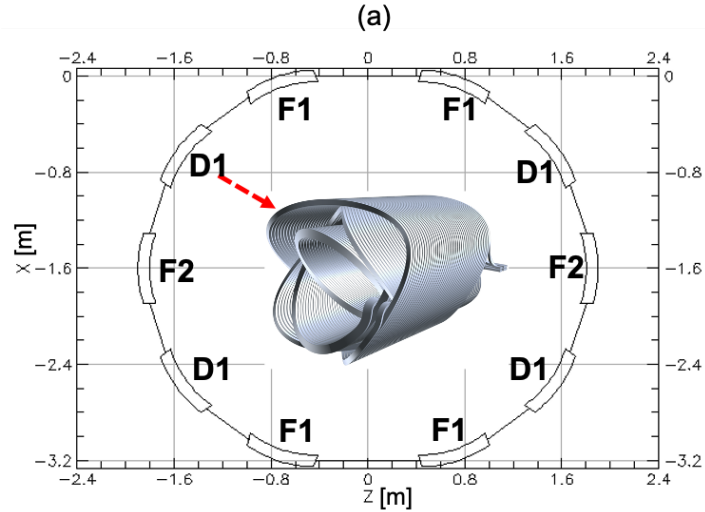

Magnet strength

Magnet	Dipole B_y [T]	Q grad. [T/m]
F1	2.12	2.59
D1	2.12	-2.59
F2	2.12	5.19

Bending angle = 36°

$$\gamma_t = 1.19108$$

$\gamma_t \neq \gamma$ This particular solution isn't isochronous, but not far!

$$\gamma = 1.01052$$

Beampipe aperture 0.2 m; $D_{x_{\max}}=2$ m \rightarrow momentum acceptance = 5%

T1.3. Study of beam dynamics

T1.3.3. Ring simulations

Previous studies considering the configuration based on curved CCTs with quadrupole triplet

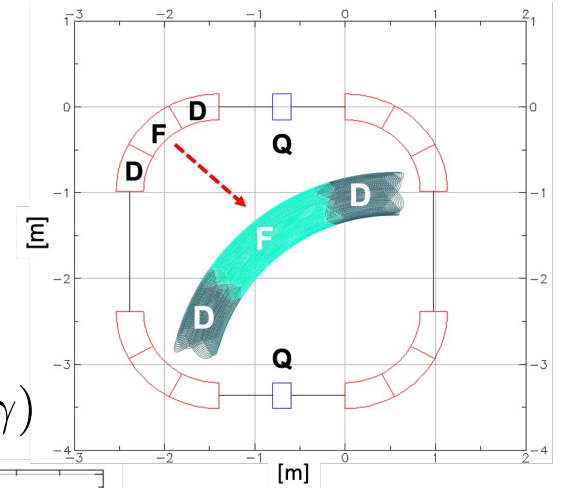

High momentum mode

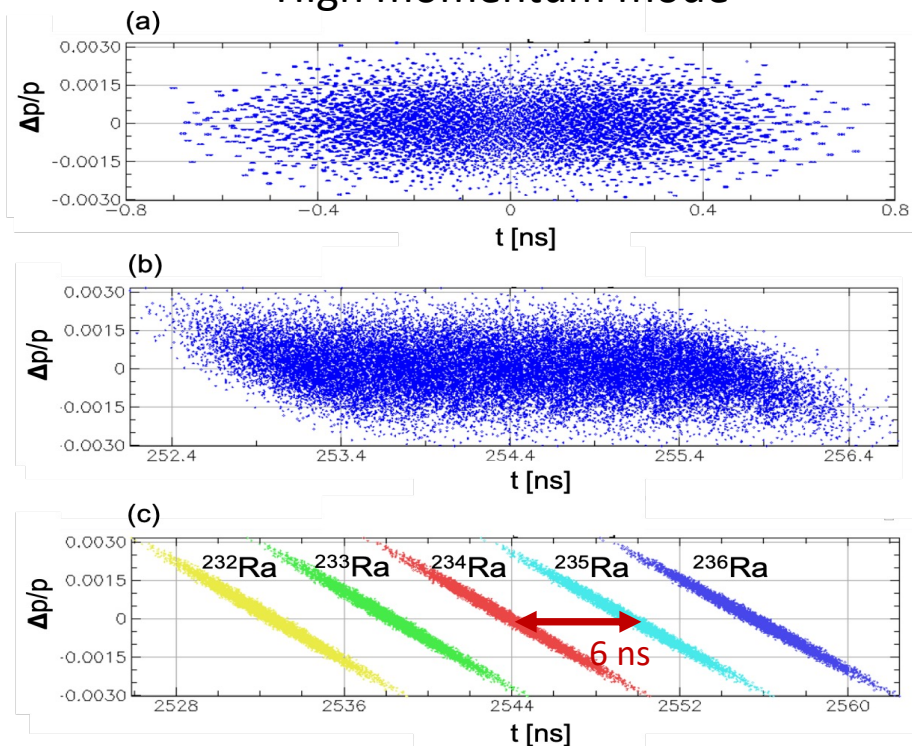

Isochronous mode ($\gamma_t \approx \gamma$)

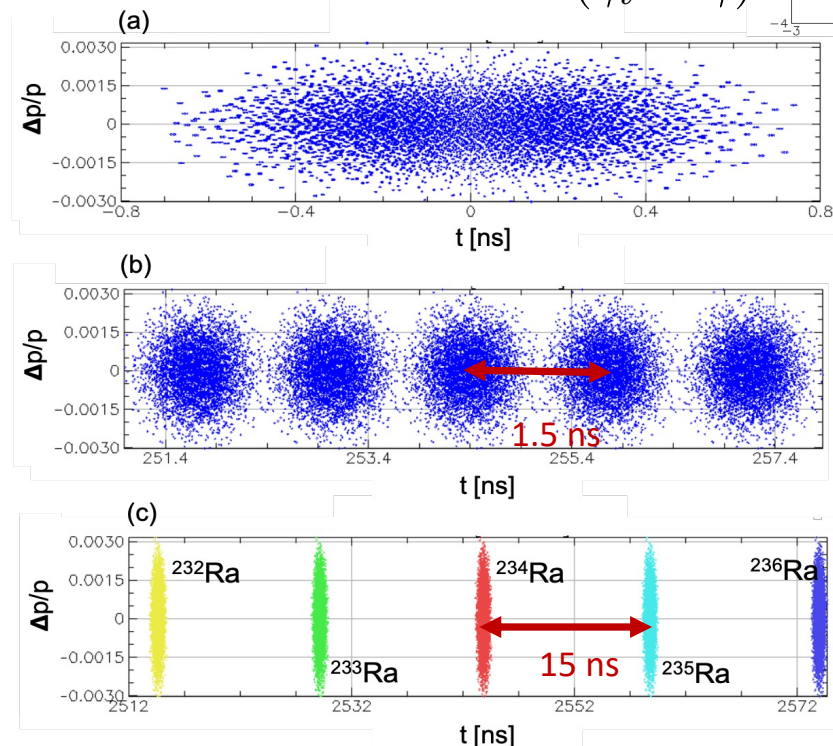

Initial longitudinal phase space

1 turn (254.4 ns)

10 turns (2544 ns)

Proc. IPAC2023, TUPA050

T1.3. Study of beam dynamics

T1.3.3. Ring simulations

Tracking simulations for configuration of 10 short (580 mm) CCT magnets

Injection, 0 turns

Gaussian distribution

5 isotopes of radium: $^{232-236}\text{Ra}$

5000 macroparticles per isotope

^{234}Ra in reference orbit

Kinetic energy = 10 MeV/u

Transverse emittance $(x,y) = 5$ mm-mrad

RMS longitudinal size $\sigma_z = 0.01$ m

RMS Momentum spread $\sigma_{\Delta p/p} = 0.01\%$

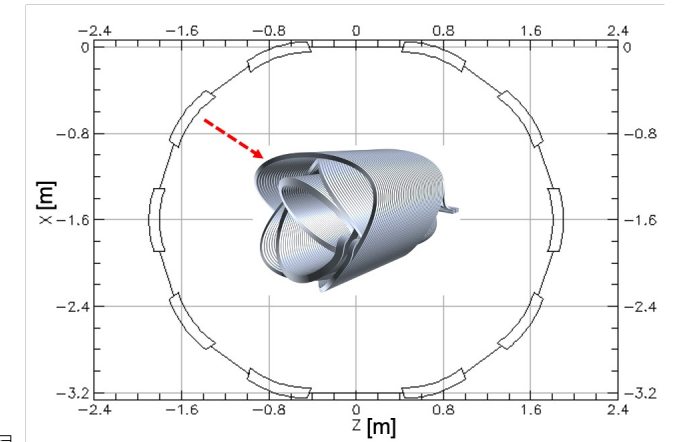

Longitudinal phase space

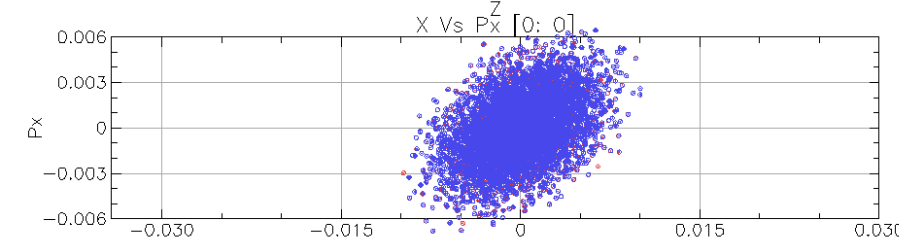
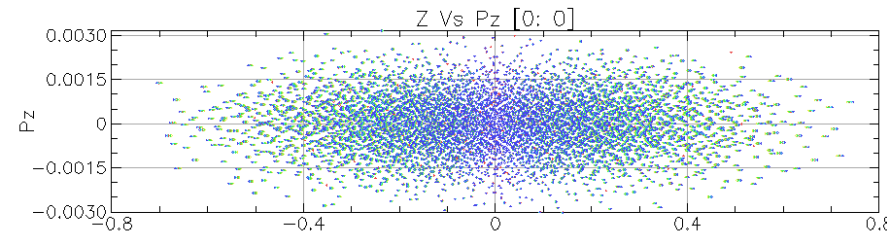

x- p_x phase space

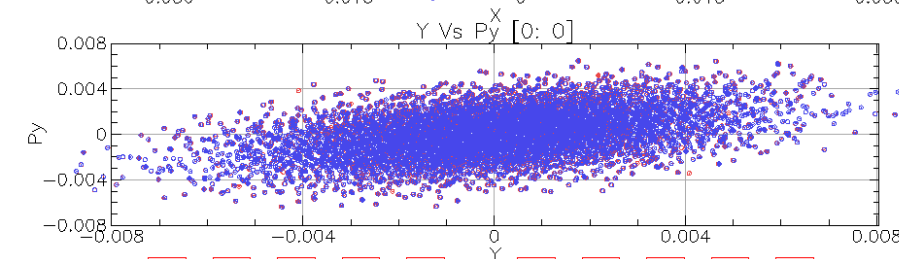

y- p_y phase space

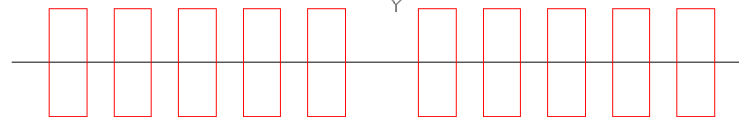

T1.3. Study of beam dynamics

T1.3.3. Ring simulations

Tracking simulations for configuration of 10 short (580 mm magnetic length) CCT magnets

1 turn (267 ns)

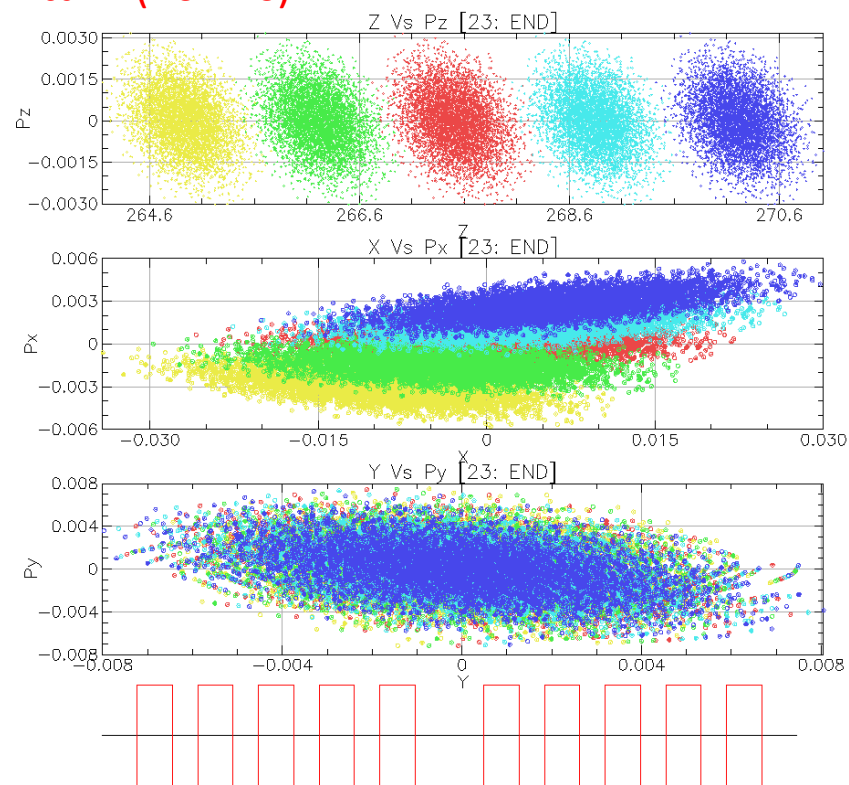

10 turns (2670 ns)

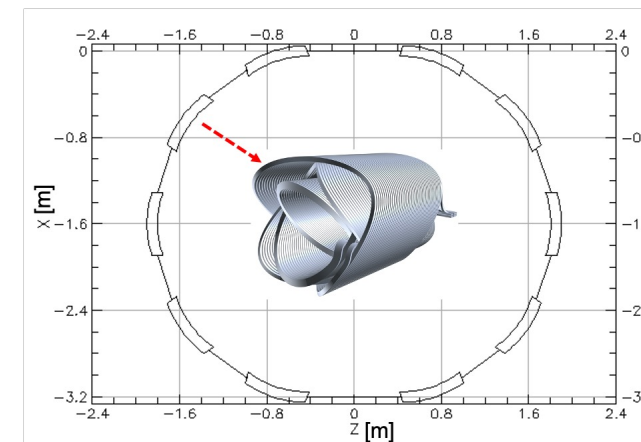
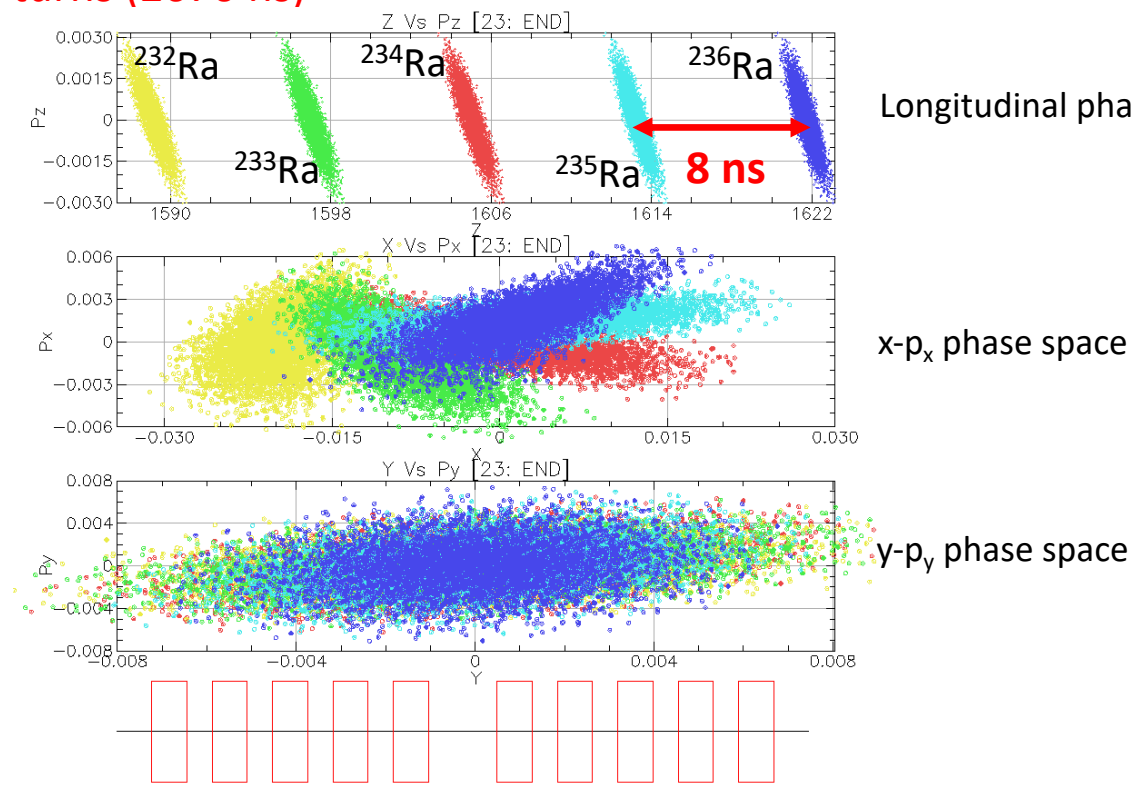

Longitudinal phase space

x- p_x phase space

y- p_y phase space

T1.3. Study of beam dynamics

Towards more realistic simulations

Considering the **3D magnetic field map of the CCT element**. Generated using the software Rat GUI
Example provided by Nikkie Deelen (Little Beast engineering) and Glyn Kirby (CERN)

We are able to import this 3D magnetic field map into different accelerator codes: BMAD, RF-Track and COSY Infinity.

Multipolar optimisation for 36-degree curve trajectory

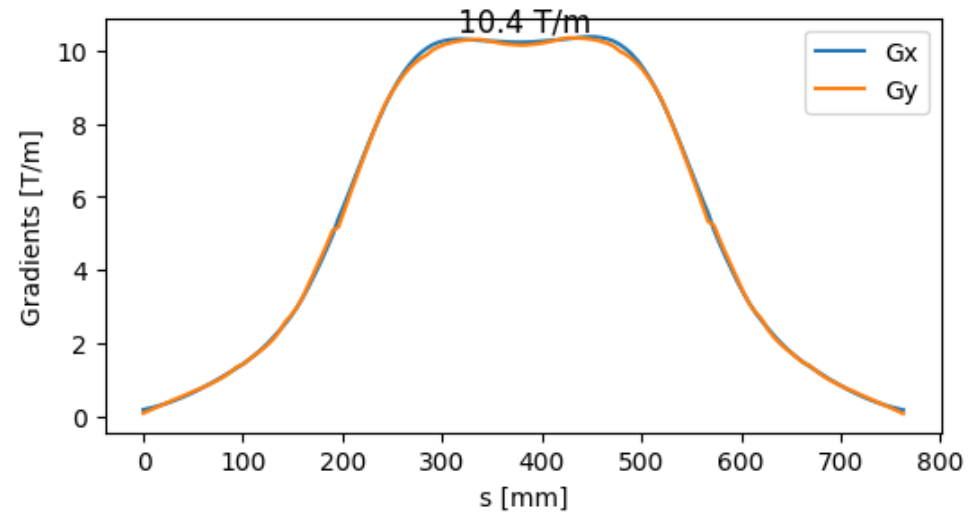
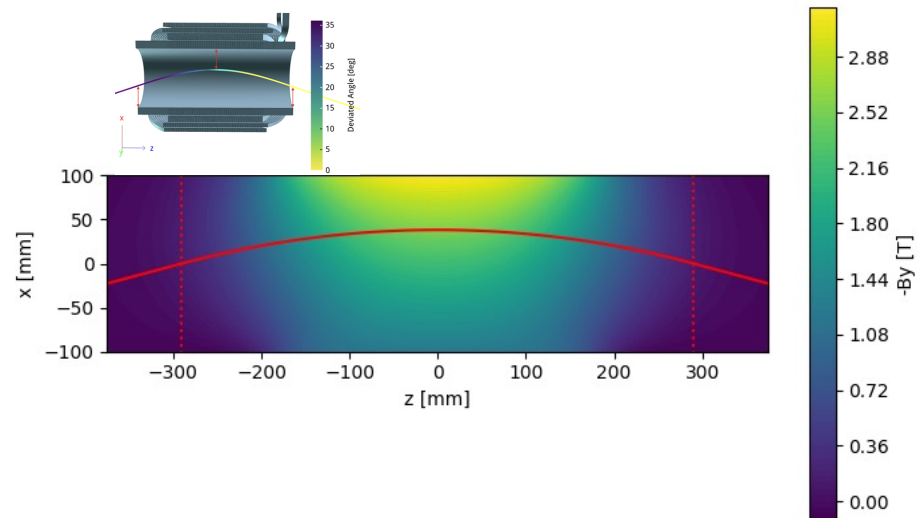

Ongoing study: benchmarking between the usual transfer matrix approximation and a more realistic 3D field map. Somehow this is also relevant for T1.7 (High order corrections to beam dynamics)

T1.3. Study of beam dynamics

Towards more realistic simulations

Start-to-end simulations. First step: **G4 Interaction modeling in SEC.** This would allow us to obtain a more realistic beam and reaction product distribution to be injected into the ring

Beam and environment parameters:

- 1×10^7 of Ra-232 (z-axis)
- Gen. Part. at 25 cm of target and 1mm of $\sigma(xy)$
- Kenergy of 2.32 GeV and 1% of $\sigma(Ken)$
- Vacuum of 5×10^{-8} mbar

Physical phenomena:

- Neutron capture: (n,p); (n,d); (n,t)
- Proton capture: (p,n)
- Elastic interactions

1st event: Ra-232 cross de target

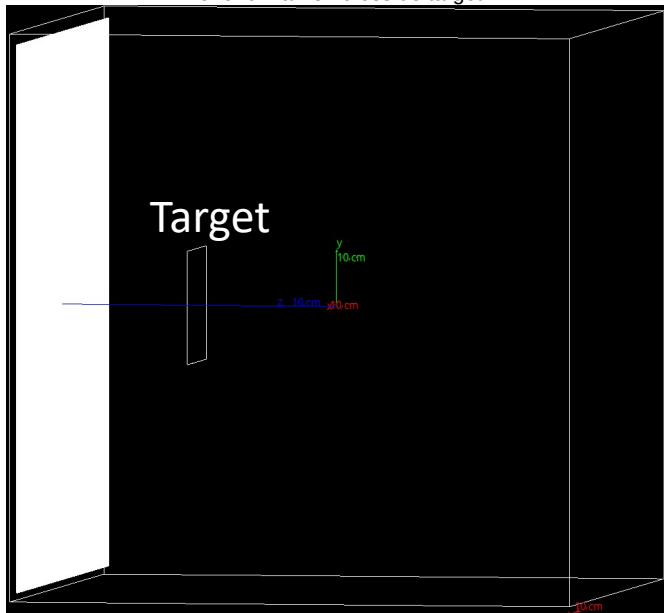

Target:

- C2D4 of plastic material at 98% (2% of H)
- Thickness size of 1.057 mg/cm²

Ideal simple detector was used for the tracking.

- 200 cells with 4.8 mm of size in xy-axis and 1 mm in z-axis.

Geant4 code:

- Data libraries of G4TENDL1.4 (d, t) and G4TENDL4.7
- Physics List: em, decay, hadron (QGSP_BIC), ion_HP and ion_elastic

2nd event: products of the collision (e, p, D, isotopes)

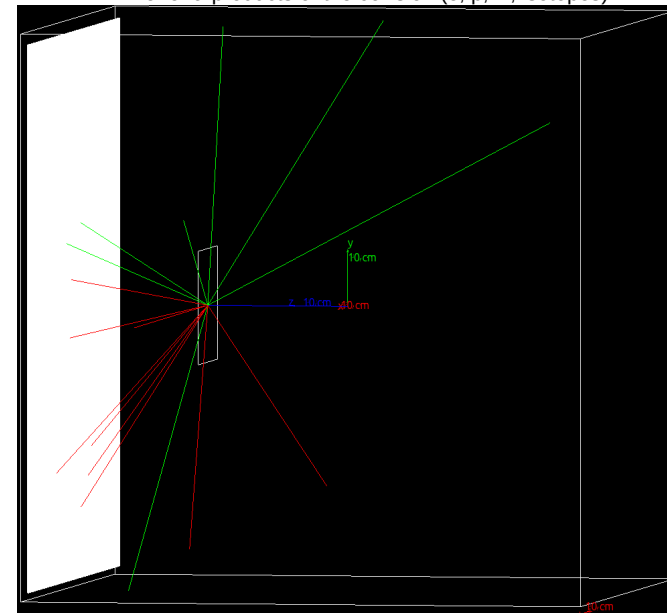

T1.3. Study of beam dynamics

Towards more realistic simulations

Start-to-end simulations. First step: **G4 Interaction modeling in SEC.** This would allow us to obtain a more realistic beam and reaction product distribution to be injected into the ring

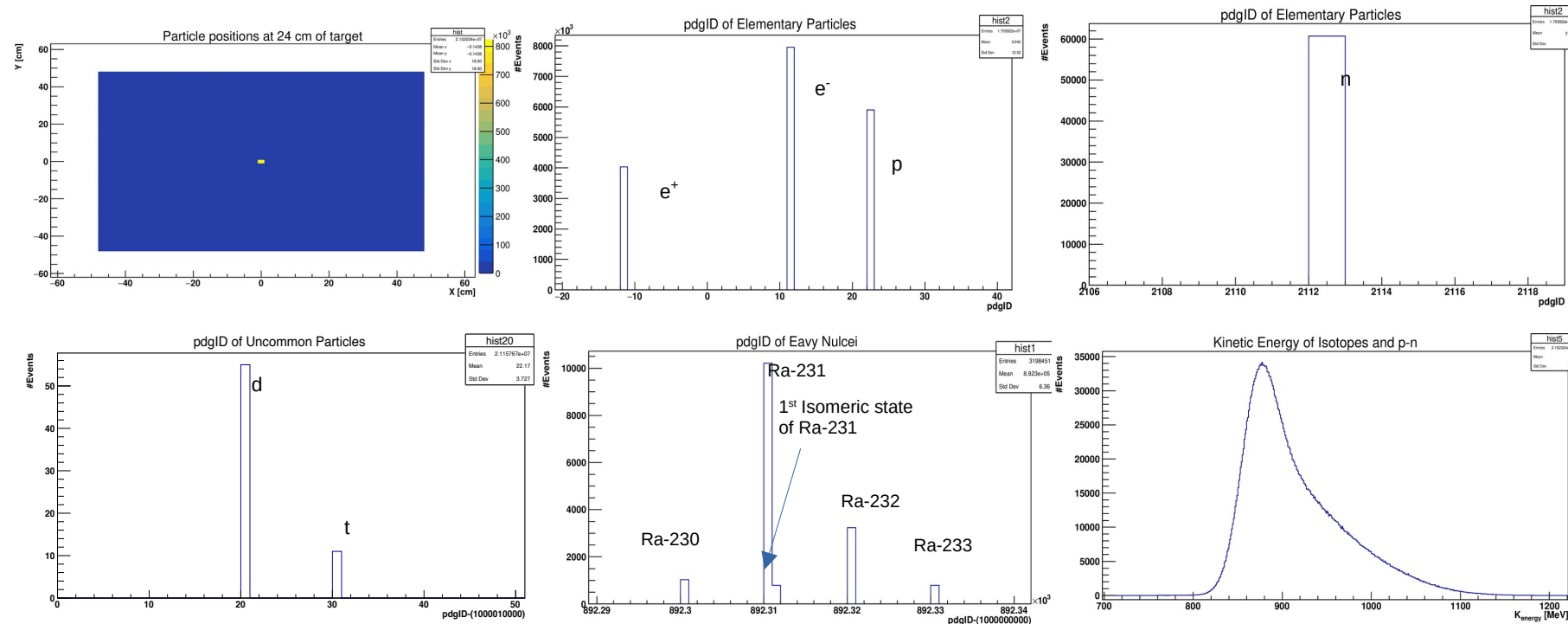

Geant4 uses extrapolated data from HEP.

Reaction Rate:

- Realistic data of the beam with the target : 1/10.000 (0.01%)
- Simulation data of a bunch with target: 0.112% taking into account isotopes only and 60% taking into account isotopes and protons

Suggestion for a program adapted to 10 MeV/u : <https://nptool.in2p3.fr/manual/installation/>

T1.4. Selection of configurations

The ISRS Zoo

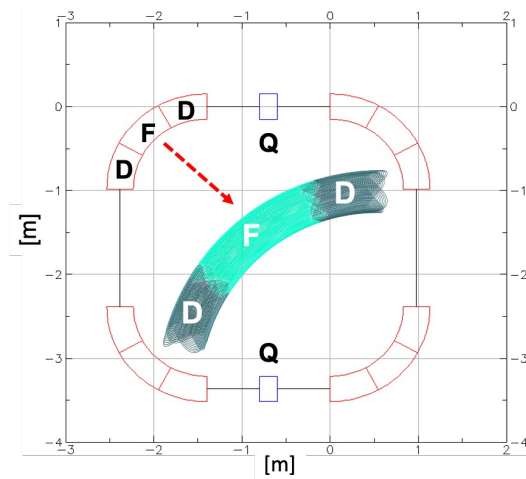

4 curved CCT magnets (90 deg. bend)

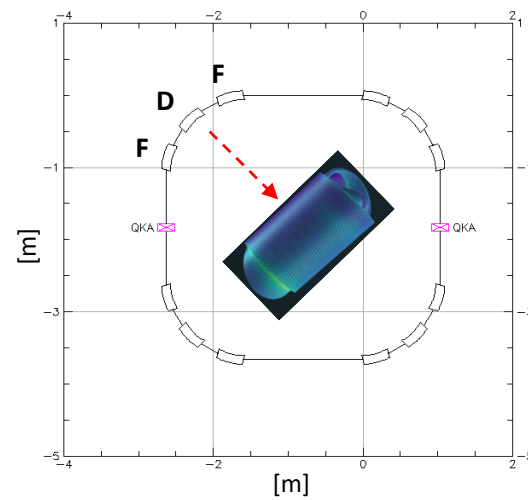

12 straight 350 mm magnetic length
CCT magnets (30 deg. bend)

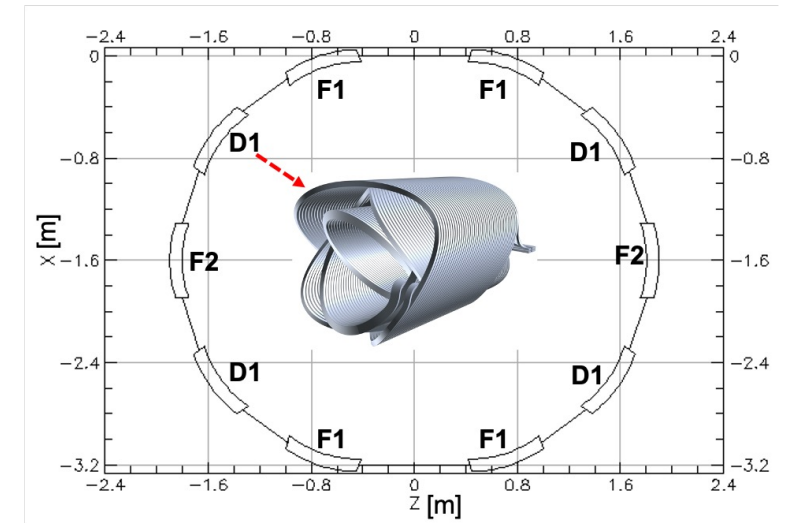

10 straight 580 mm magnetic length
CCT magnets (36 deg. bend)

Step by step we are converging on a final design adapted to the requirements

T1.5. Study of Injection/Extraction

- Challenging design due to stringent requirements (limited space, beam time structure, apertures, ...)
- Depending on the operation mode of the ring (DC or pulsed mode) different alternatives should be considered
- It is a project by itself
- **Ongoing studies: Briefly presented by Fazel Taft**

T1.6 Beam diagnostics

- Select beam diagnostics devices and positions. Limited space
- Constraints due to cryo-magnetic systems and large beam section (>100 mm)
- Preferably **non-interceptive devices**
- **Activities on this task will begin within the next few months (in collaboration with The University of Liverpool and CI, UK)**