



Beam dynamics

Progress Report WP1

Javier Resta-López

ICMUV, University of Valencia, Spain



ISRS Workshop
19th June 2025



Financiado por
la Unión Europea
NextGenerationEU

Introduction

Selection of machine layouts and lattices

ISRS ring design. Different candidates

4 curved CCT magnets (90 deg. bend)

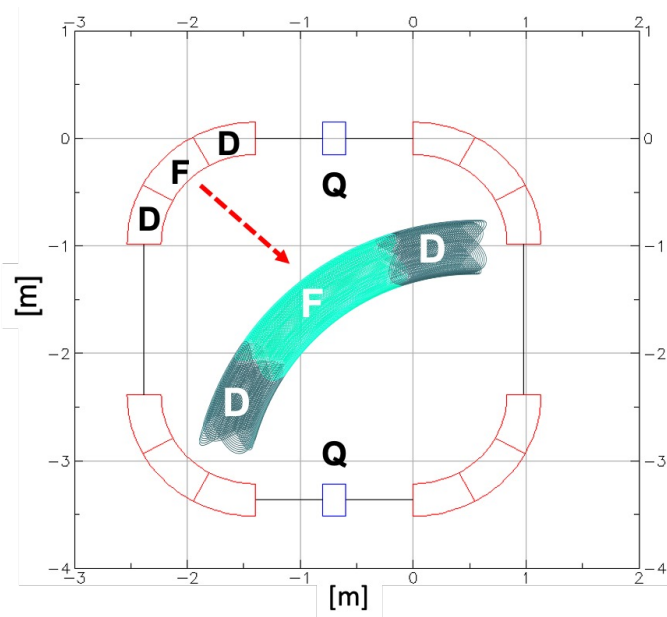

12 straight 350 mm effective magnetic length CCT magnets (30 deg. bend)

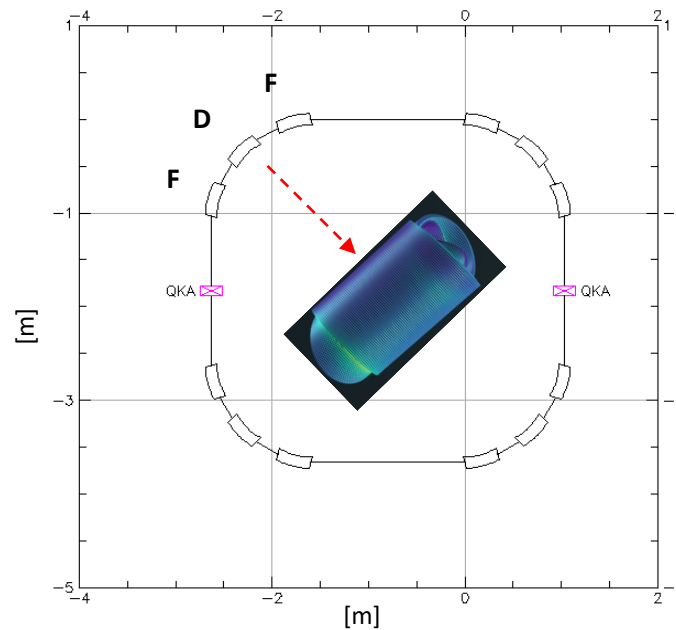

10 straight 580 mm effective magnetic length CCT magnets (36 deg. bend)

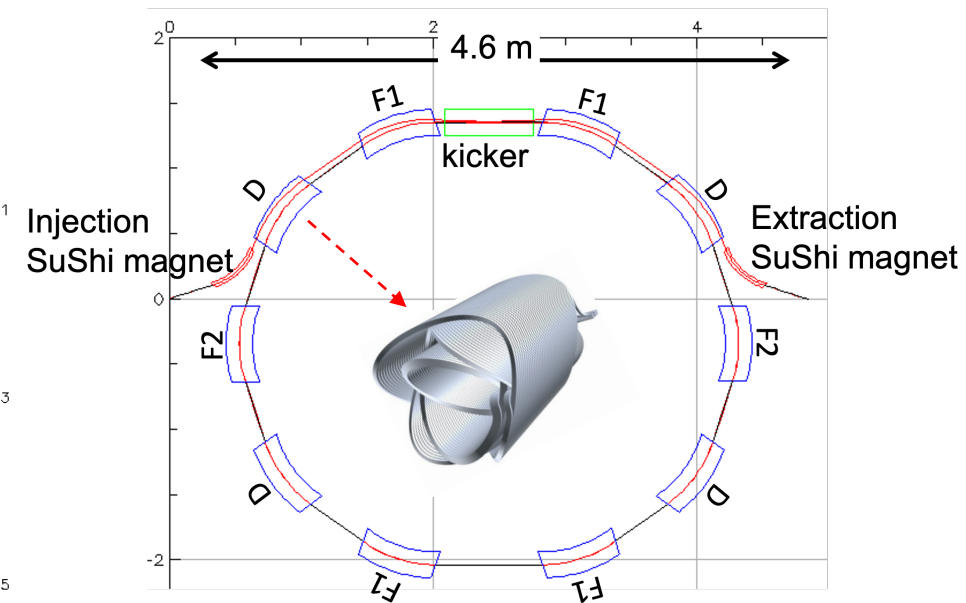

Magnet models (based on the software Rat GUI) revealed that the effective CCT magnetic length must be higher than 500 mm to safely operate the magnet in terms of thermo-mechanical parameters obtaining the required dipolar and quadrupolar strengths

Baseline ISRS layout

Based on 580 mm effective magnetic length CCT magnets

MAGDEM

(See progress report of WP2)

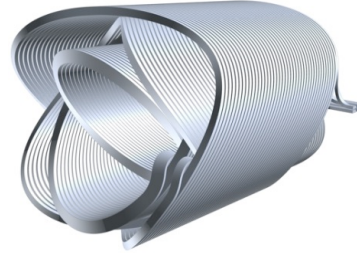

| Parameter | Value |
|---------------------------|----------------------------------|
| Total length | 720 mm |
| Effective magnetic length | 580 mm |
| bore aperture diameter | 200 mm |
| Mechanical diameter | 900 mm |
| Dipole field strength | < 2.3 T |
| Beam bending capacity | 36 degrees |
| Quadrupole field gradient | < 9.8 T/m |
| Operating current | 100 A |
| Cryogenic temperature | 4.5 K |
| Field error | Below 1 unit |
| Magnet type | Nested dipole and quadrupole CCT |

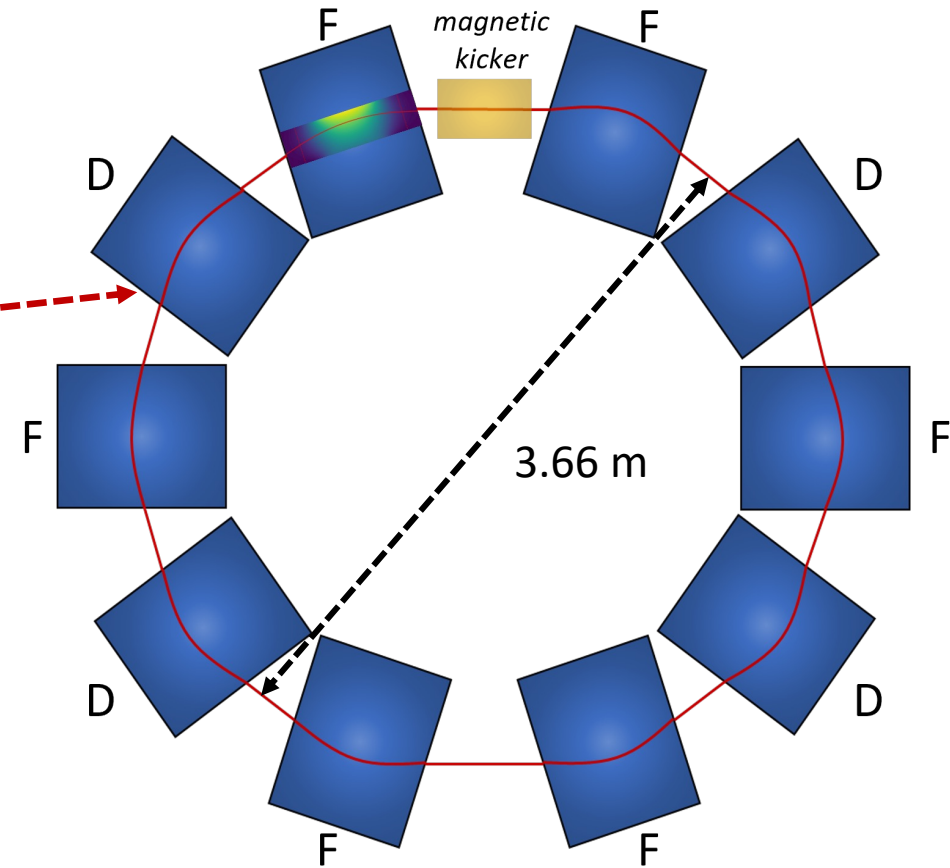
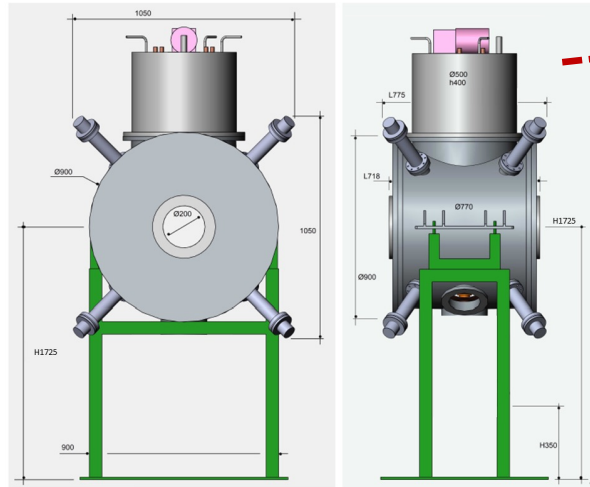

Baseline ISRS optics

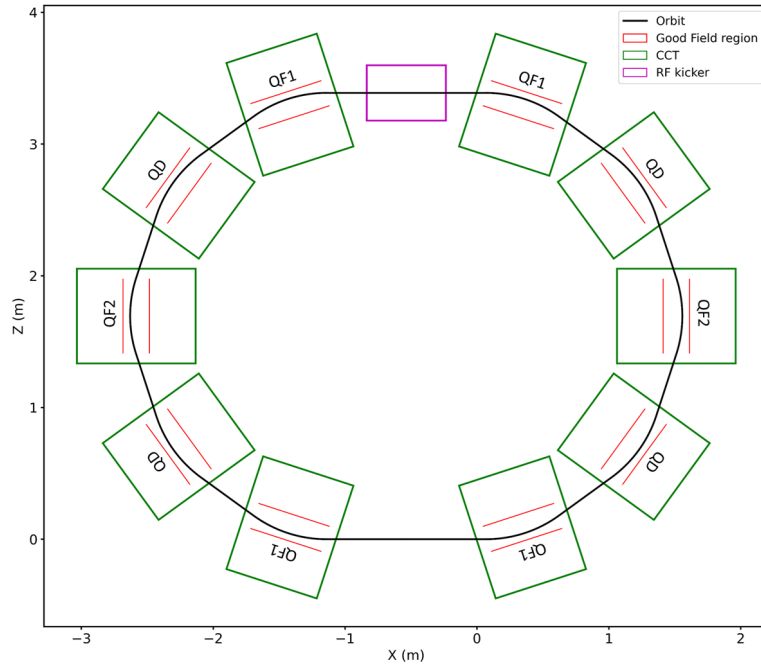

Matched for a reference ion $^{234}\text{Ra}^{53+}$ at 10 MeV kinetic energy
BMAD code

Isochronous

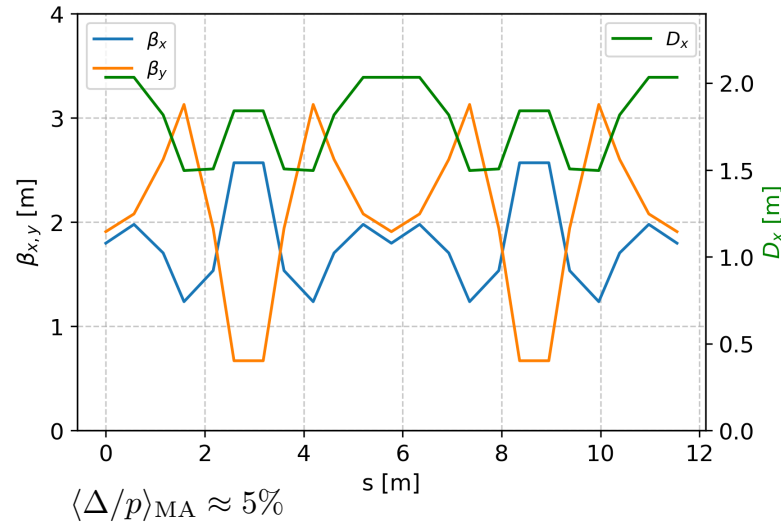

Quasi-isochronous

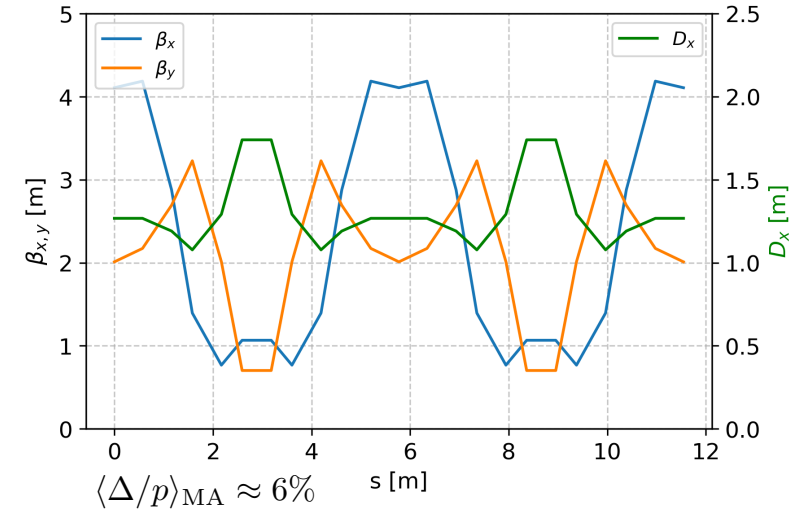

Isochronicity condition $\gamma_t \approx \gamma$

Momentum acceptance (linear optics):

$$\text{BP aperture} = 2(\Delta x)_{\text{max}} = 2D_x^{\text{max}} \left\langle \frac{\Delta p}{p} \right\rangle_{\text{MA}}$$

| | Isochronous | Quasi-Isochronous |
|-----------------------|-------------|-------------------|
| Ring circumference | 11.54 m | |
| Beam energy | 10 MeV/u | |
| Magnetic rigidity | 2.05 T·m | |
| Beam γ | 1.01054 | |
| Transition γ_t | 1.01054 | 1.16268 |
| Max Dispersion | 2.03 cm/% | 1.7 cm/% |
| Betatron tune Q_x | 1.03 | 1.15 |
| Betatron tune Q_y | 1.30 | 1.21 |
| Dipole field | 2.1266 T | |
| Quadrupole field QF1 | 2.273 T/m | 2.520 T/m |
| Quadrupole field QD | -2.001 T/m | -1.744 T/m |
| Quadrupole field QF2 | 3.696 T/m | 3.770 T/m |

Baseline ISRS optics

Simulation code benchmarking and non-linear optics analysis

GICOSY code. Nonlinear effects studied up to 3rd order

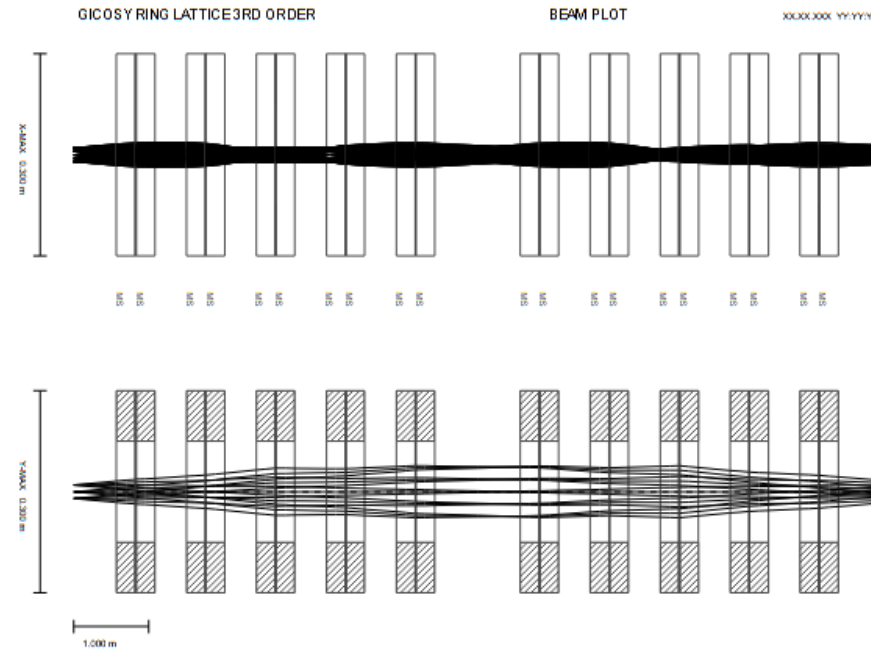
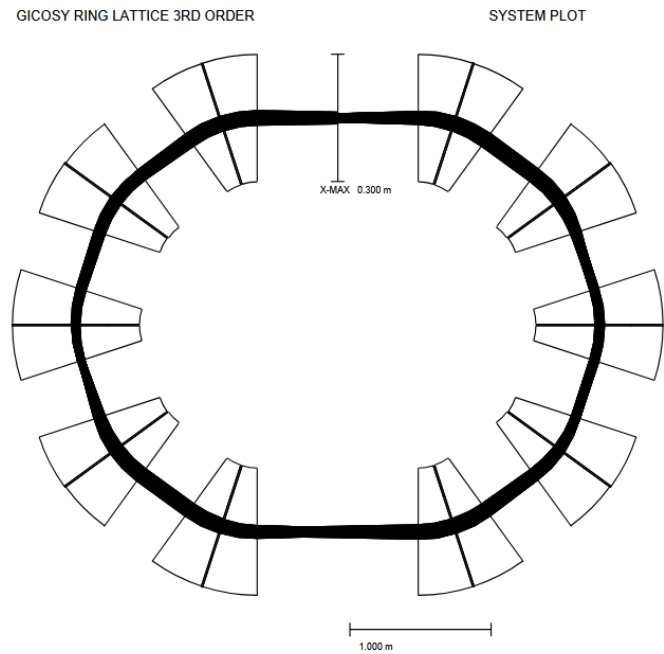

Code benchmarking has also been performed in the context of the Ion Test Bench (IONTB): T2.3 (WP2)

T. Kutukian-Nieto et al.

Optics characterisation: Tune diagram.

Isochronous configuration vs quasi-isochronous

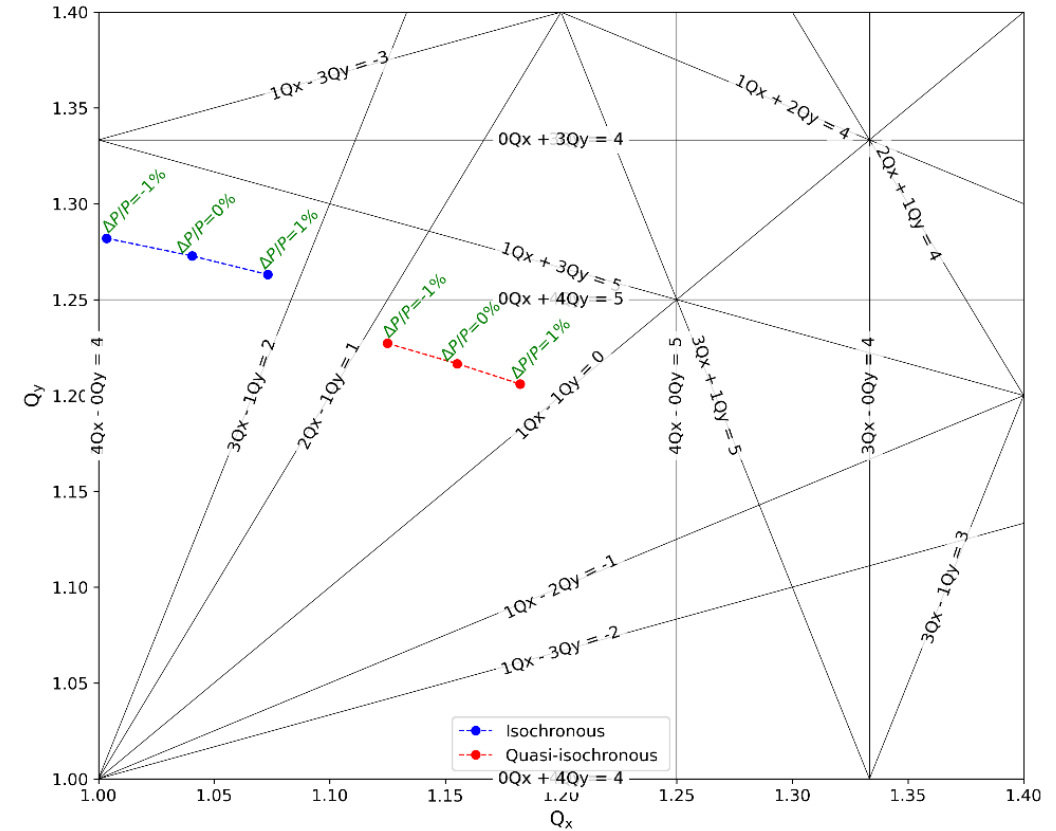
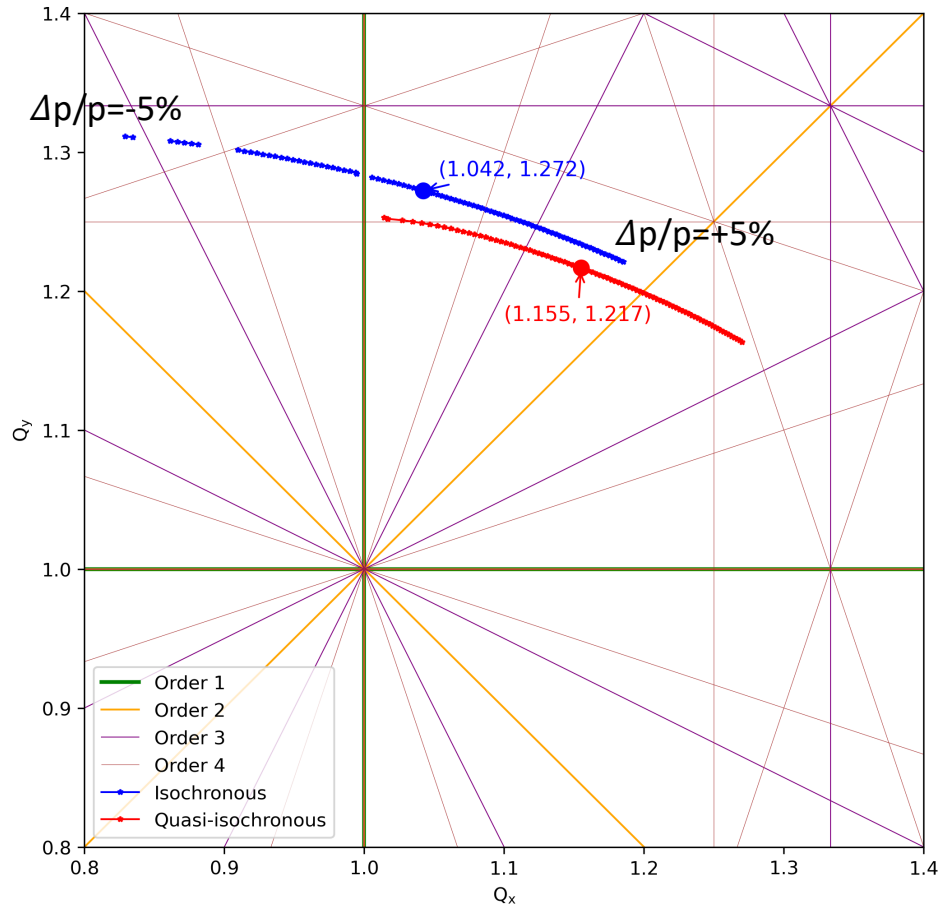

Considering potential orbit instabilities due to resonance effects, momentum acceptance $\approx 1\%$

Optics characterisation: Chromaticity

Isochronous configuration vs quasi-isochronous

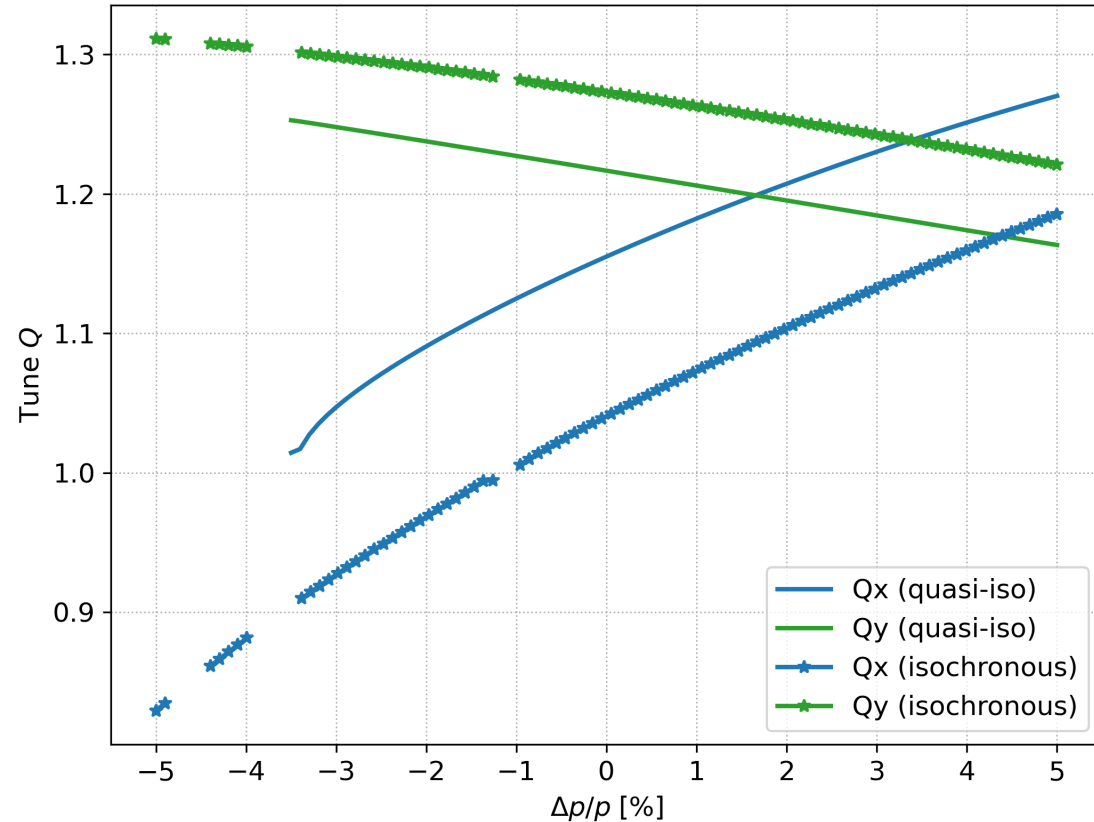

$$\xi_{x,y} = \frac{dQ_{x,y}}{d(\Delta P/P)}$$

$$(\xi_x, \xi_y)_{\text{isochronous}} = (3.3884, -0.9465)$$

$$(\xi_x, \xi_y)_{\text{quasi-isochronous}} = (2.8585, -1.0636)$$

To increase momentum acceptance,
avoiding critical resonances,
chromaticity correction with sextupoles
will be necessary

Tracking simulations

Isochronous configuration

Ideal conditions. Monochromatic beams

Input particle distribution:

Gaussian distribution
5 isotopes of radium: $^{232-236}\text{Ra}$
5000 macroparticles per isotope
 ^{234}Ra in reference orbit
Kinetic energy = 10 MeV/u
Transverse emittance (x,y) = 5 mm-mrad
RMS longitudinal size $\sigma_z = 0.01$ m
RMS Momentum spread $\sigma_{\Delta p/p} = 0.01\%$

BMAD simulation code

Isotopes separation by ToF after 10 turns

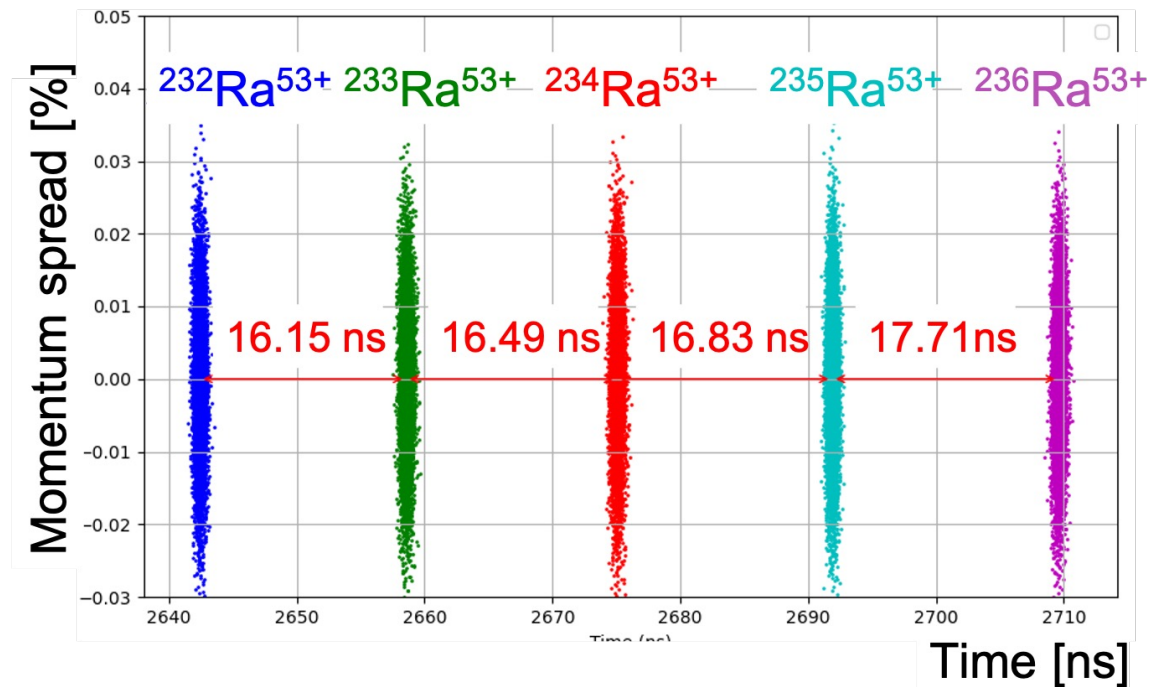

Tracking simulations

Isochronous configuration

1% RMS momentum spread

Different charge states

Xsuite code

F. Taft et al, Proc. of IPAC25, Taipei, Taiwan, 2025, paper MOPS092

Isotopes separation by ToF after 10 turns

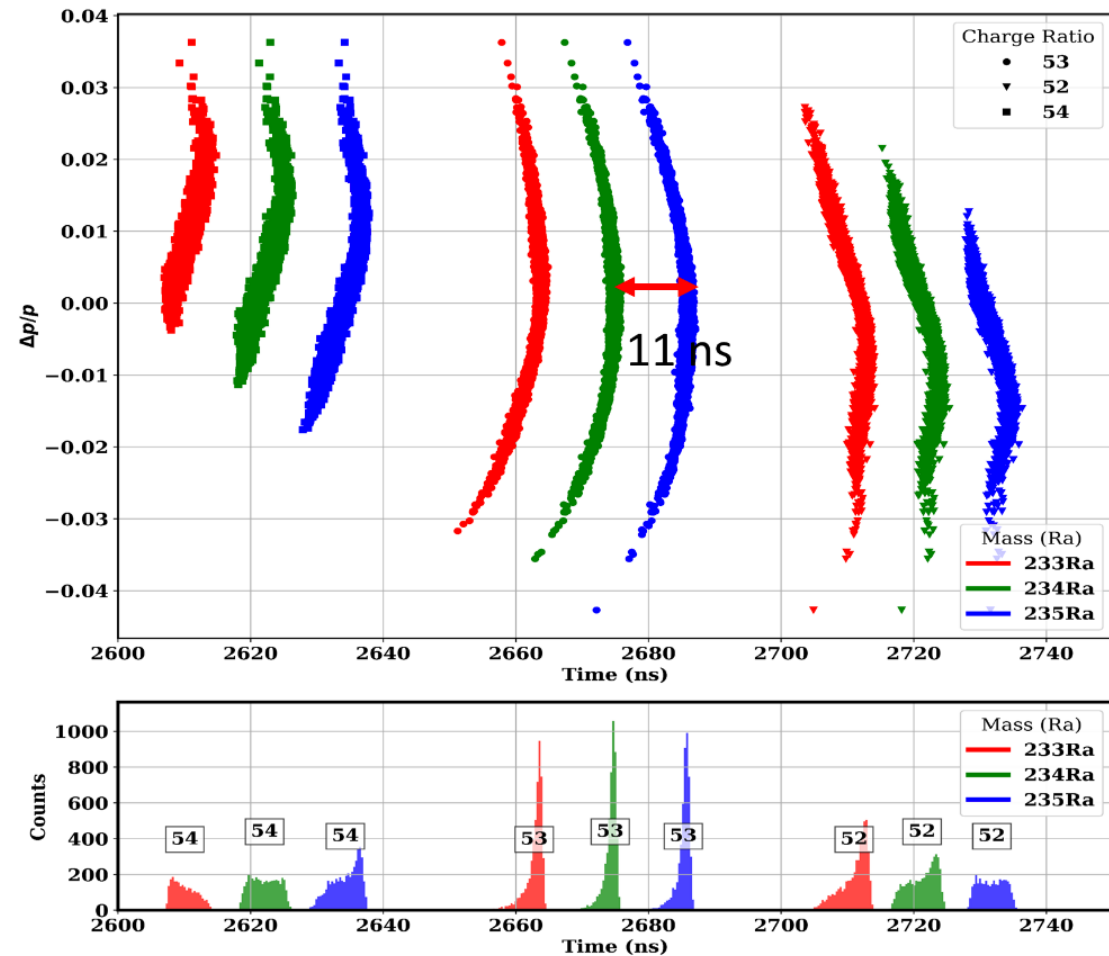

Tracking simulations

Quasi-isochronous configuration

1% RMS momentum spread

Different charge states

Xsuite code

Isotopes separation by ToF after 10 turns

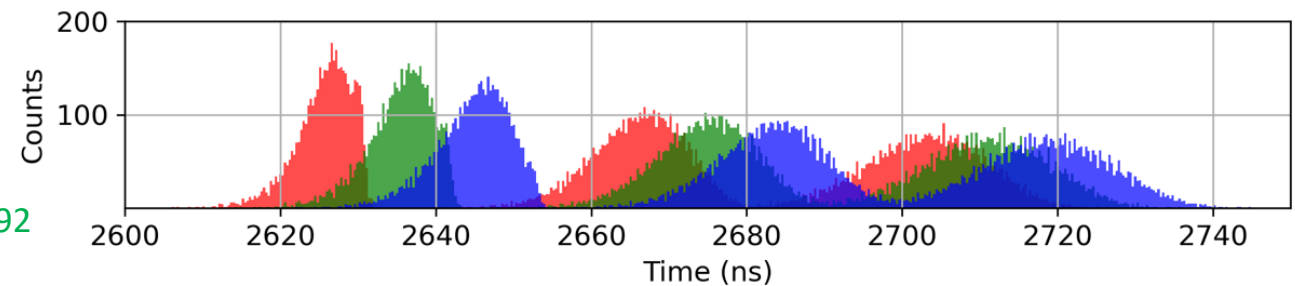
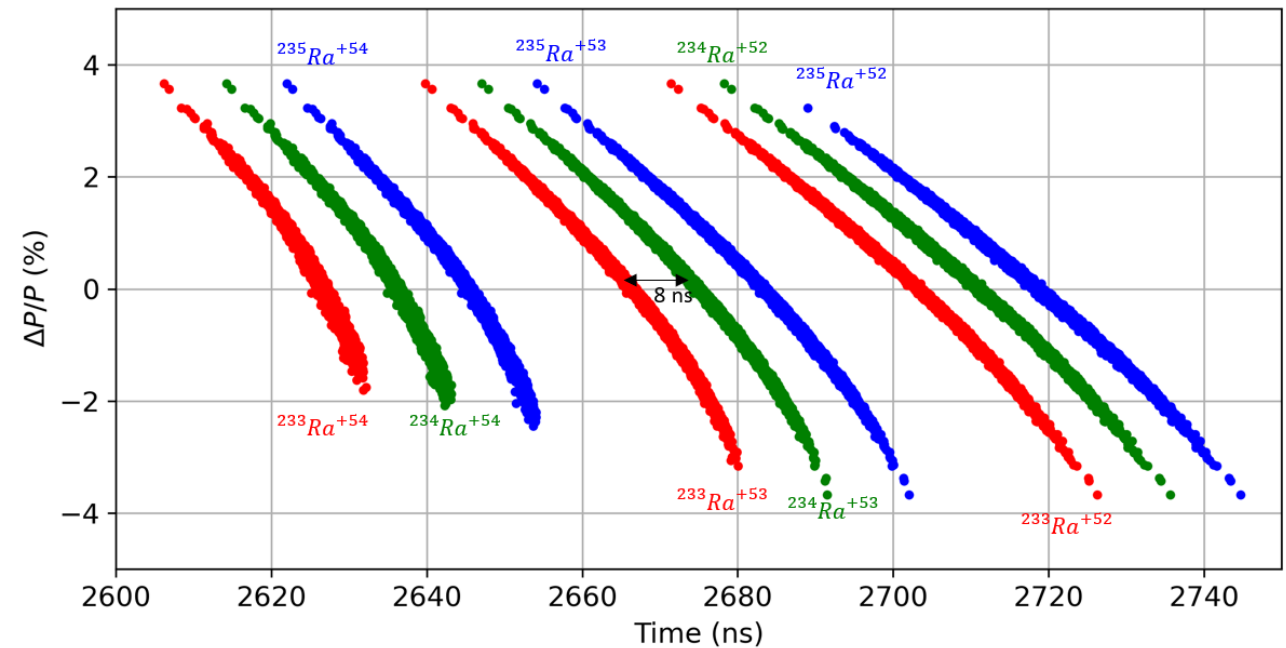

F. Taft et al, Proc. of IPAC25, Taipei, Taiwan, 2025, paper MOPS092

Tracking simulations. Reaction chamber + ISRS

MC simulation tool (developed in collaboration with UHU)

- Cross-section calculated using the codes EMPIRE (compound reactions) and FRESKO (direct reactions)
- Energy-loss effects evaluated using the code SRIM

Phase-space distributions of reaction products

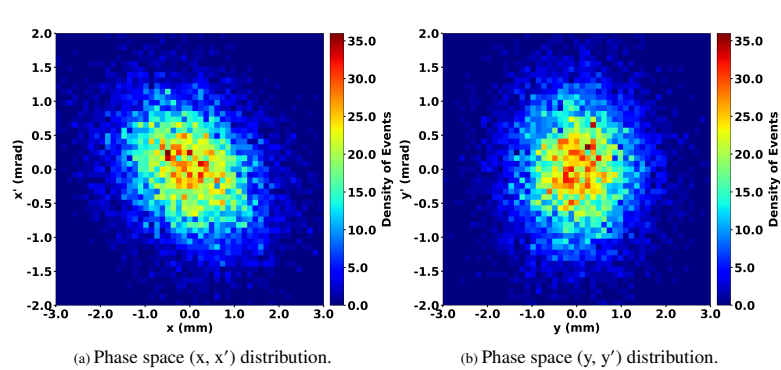

SEC chamber with C_2D_4 target (98% purity)

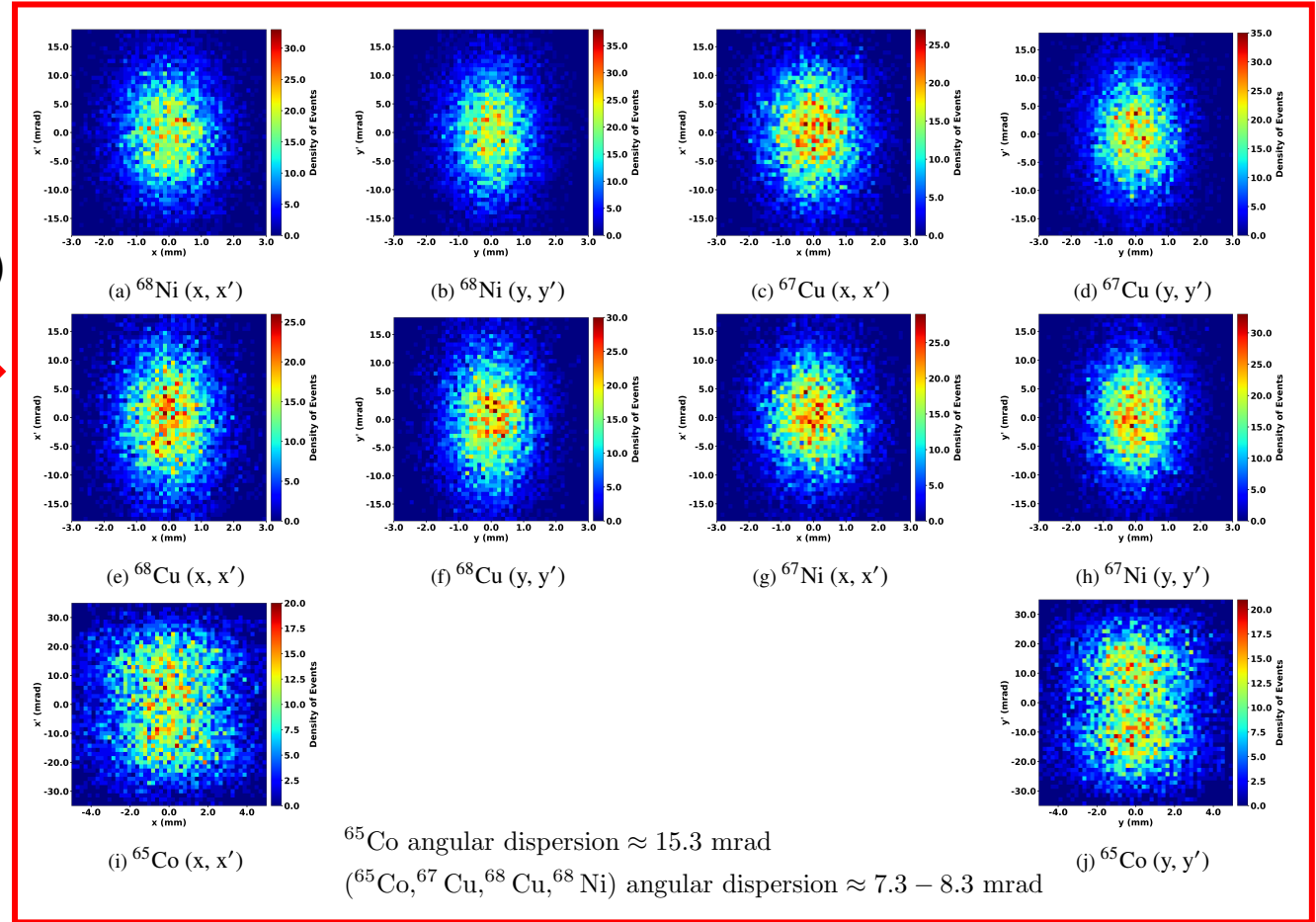

Input XT03 HIE-ISOLDE ^{68}Ni beam parameters at 10 MeV/u

| Twiss parameters | | | | |
|----------------------------|------------------------|----------------------|------------------------|--------------|
| (ϵ_x, ϵ_x) | (α_x, α_y) | (β_x, β_y) | (γ_x, γ_y) | $\Delta p/p$ |
| π (mm mrad) | | (m/rad) | (rad/m) | (%) |
| (0.60, 0.60) | (0.290, 0.002) | (1.54, 1.21) | (0.71, 0.83) | 0.5 |

Relatively well-collimated final beam after the target

Tracking simulations. Reaction chamber + ISRS

ToF isotope separation in ISRS after 10 turns operating in isochronous mode. RF-Track simulations

Frequency of normalised distributions in increasing order of atomic number (Z)

Case $^{68}\text{Ni}^{16+} + \text{C}_2\text{D}_4$ target

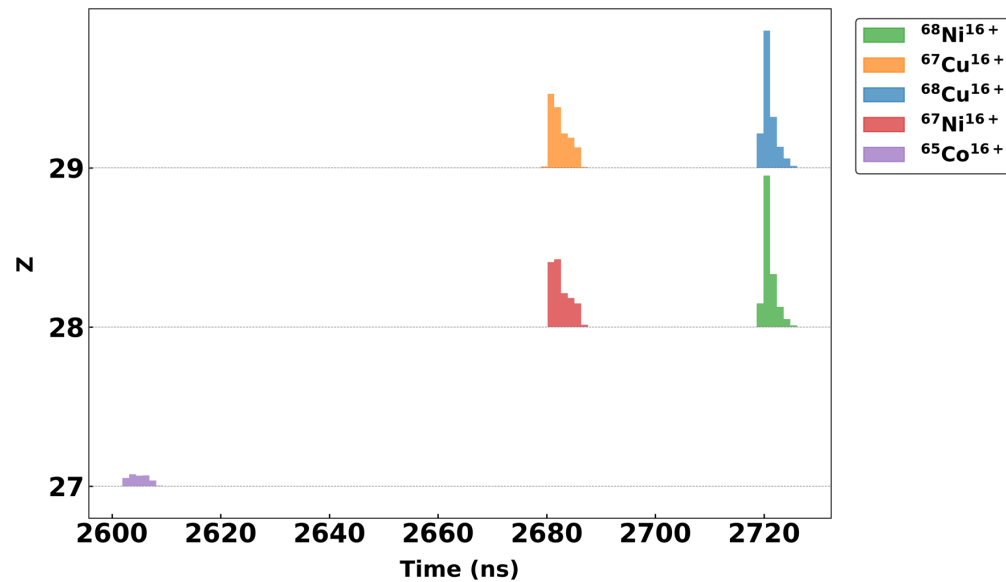

ToF resolution $\sim 1.1 \text{ ns} - 1.6 \text{ ns}$

Case $^{185}\text{Hg}^{44+} + \text{C}_2\text{D}_4$ target

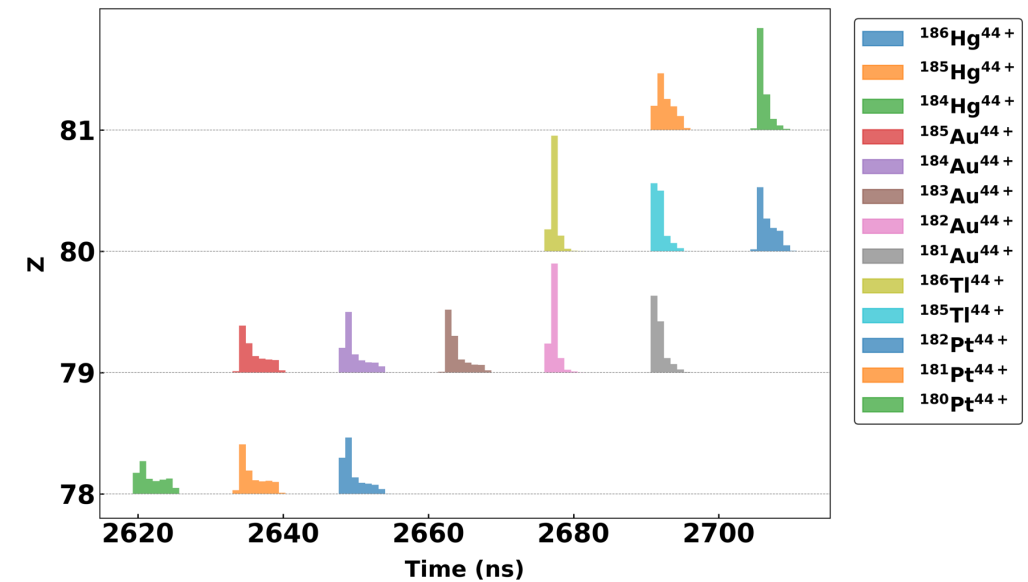

ToF resolution $\sim 0.49 \text{ ns} - 1.43 \text{ ns}$

High sensitivity of the system, enabling separation of ions with nearly identical m/q

Injection/Extraction system

Conceptual design

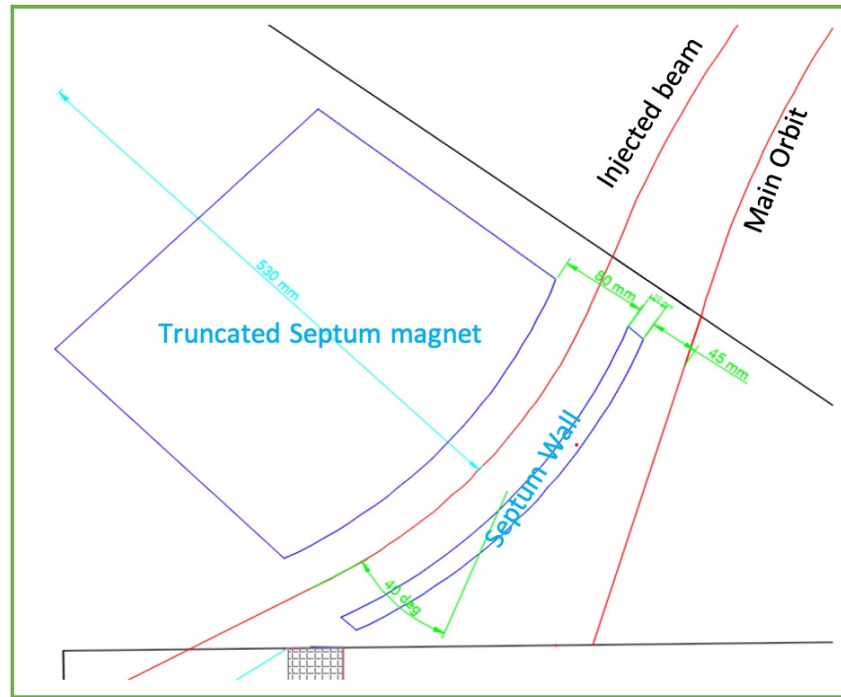

| Truncated Septum Magnet | |
|-------------------------|------------|
| Bending angle | 40 degrees |
| Effective length | 370 mm |
| Magnetic field | 3.77 T |
| Conductor material | NbTi |
| Septum wall+ coil | 20 mm |

| RF Kicker | |
|------------------|--------------------|
| Type | Magnetic RF kicker |
| Kick angle | 50 mrad |
| Length | 600 mm |
| Magnetic field | 0.16 T |
| Integrated Field | 0.10 T |
| Pulse Time | 260 ns |

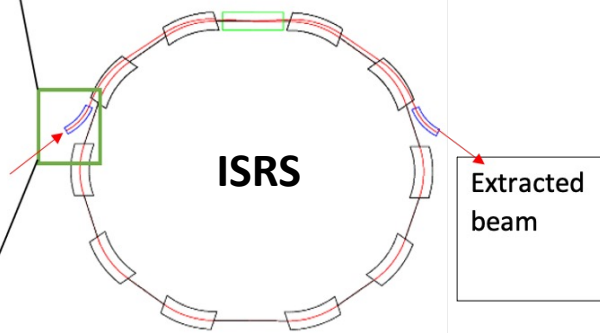

Tracking simulation: injection

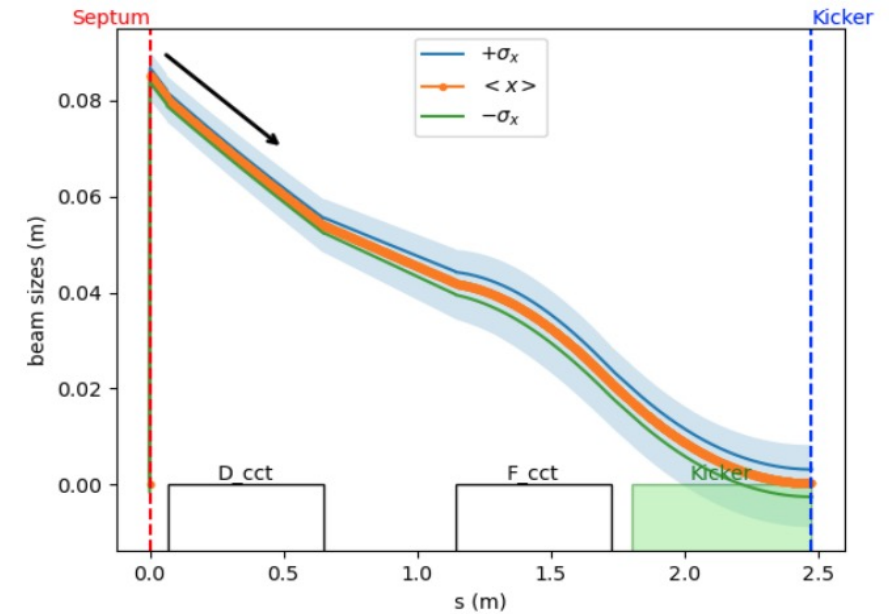

Summary

WP1: 75% completed

- Baseline ISRS design selected
- Full (linear and non-linear) characterisation of the ISRS optics
- Tracking simulations in isochronous and quasi-isochronous operation mode
- MC model of beam-target interaction. Integrated simulations of ToF isotope separation in ISRS considering realistic reaction cases
- Study of Injection/Extraction: preliminary conceptual design based on SuShi type septum and RF-kicker.

Next steps:

Optimisation of the ISRS injection/extraction system

Optimisation of the ISRS ring to effectively integrate beam diagnostic and injection/extraction systems

Start-to-end simulation: beam-target + injection + ISRS + extraction

Complete a list of error tolerances

Thanks to all the contributors

Jorge Giner-Navarro, Yanis Fontenla, Fazel Taft (University of Valencia)

Ismael Martel et al. (University of Huelva)

Teresa Kurtukian-Nieto et al. (Instituto de Estructura de la Materia, CSIC, Madrid)

Thank you for your attention!