



# Beam dynamics and optics design

## Progress Report WP1

Javier Resta-López

ICMUV, University of Valencia, Spain



ISRS Workshop  
24<sup>th</sup> Nov 2025



Financiado por  
la Unión Europea  
NextGenerationEU

# Introduction

Selection of machine layouts and lattices

**ISRS ring design.** Different candidates

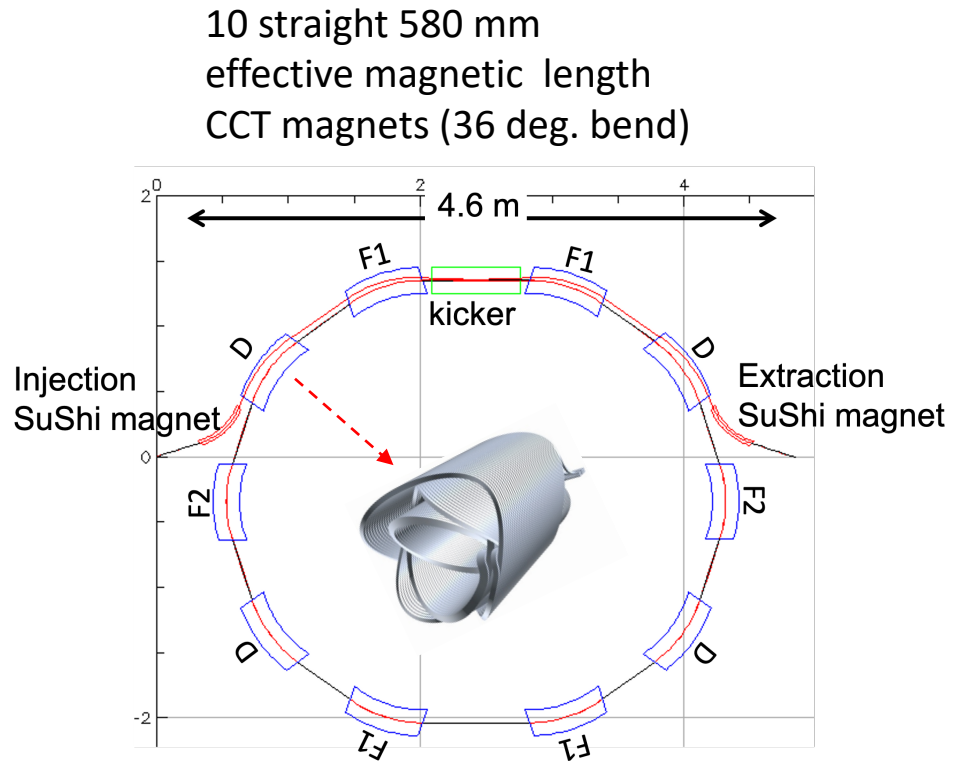
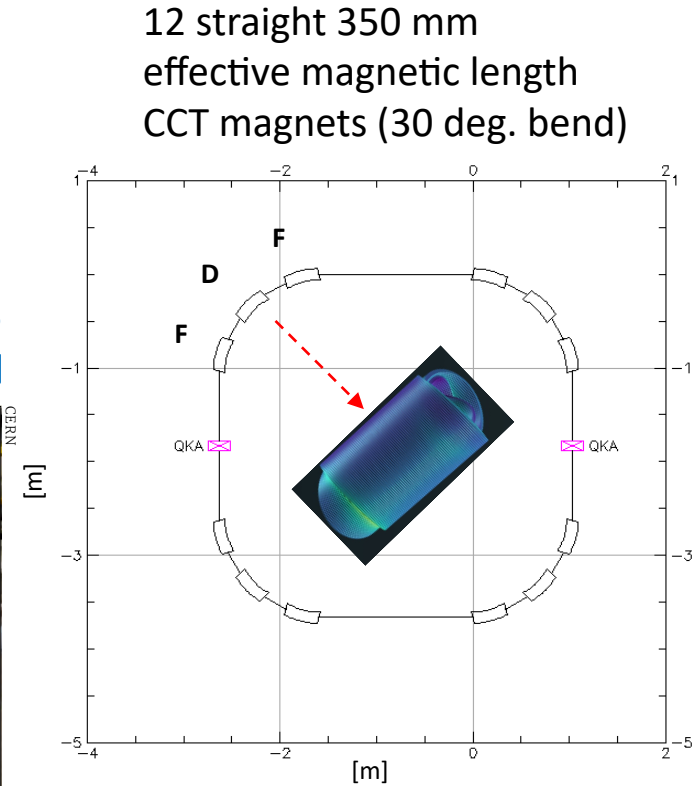
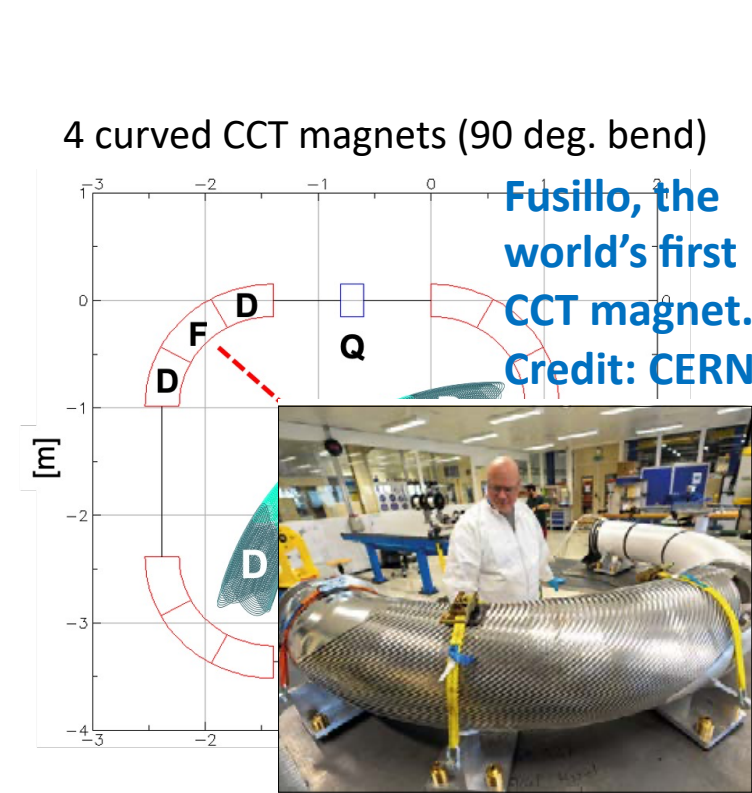

Magnet models (based on the software Rat GUI) revealed that the effective CCT magnetic length must be higher than 500 mm to safely operate the magnet in terms of thermo-mechanical parameters obtaining the required dipolar and quadrupolar strengths

# Baseline ISRS layout

Based on 580 mm effective magnetic length CCT magnets

## MAGDEM

(See progress report of WP2)

| Parameter                 | Value                            |
|---------------------------|----------------------------------|
| Total length              | 720 mm                           |
| Effective magnetic length | 580 mm                           |
| bore aperture diameter    | 200 mm                           |
| Mechanical diameter       | 900 mm                           |
| Dipole field strength     | < 2.3 T                          |
| Beam bending capacity     | 36 degrees                       |
| Quadrupole field gradient | < 9.8 T/m                        |
| Operating current         | 100 A                            |
| Cryogenic temperature     | 4.5 K                            |
| Field error               | Below 1 unit                     |
| Magnet type               | Nested dipole and quadrupole CCT |

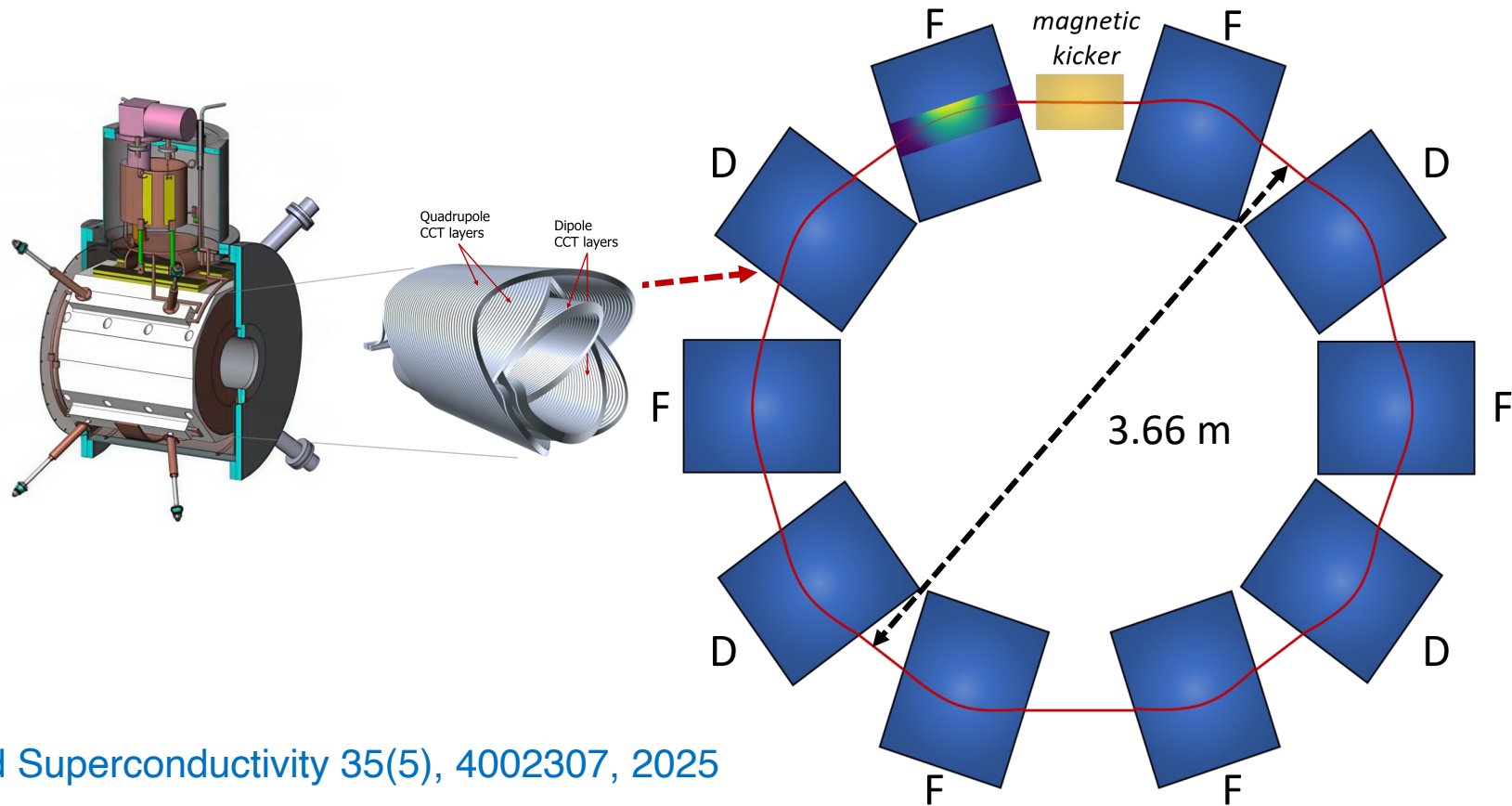

G. Kirby et al., IEEE Transactions on Applied Superconductivity 35(5), 4002307, 2025

# Baseline ISRS optics

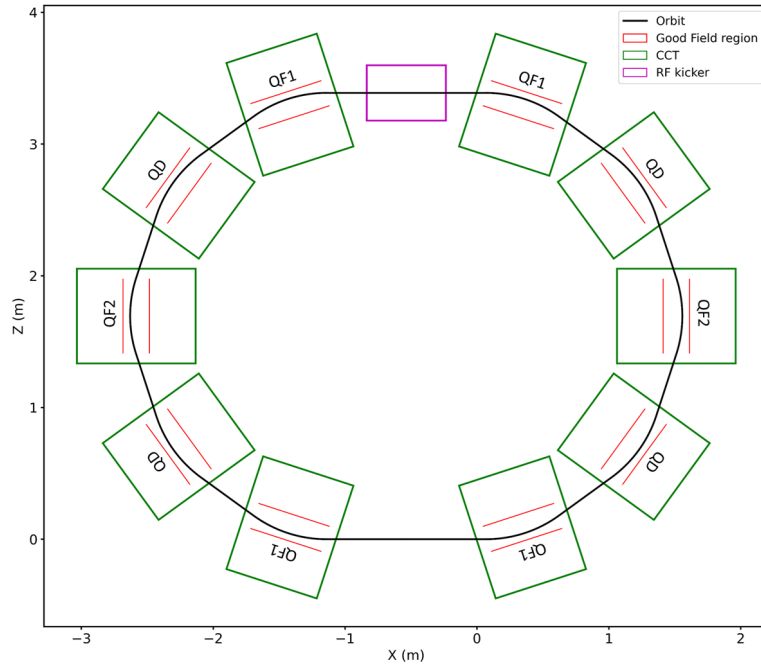

Isochronicity condition  $\gamma_t \approx \gamma$

F. Taft et al, submitted to IEEE Access

Matched for a reference ion  $^{234}\text{Ra}^{53+}$  at 10 MeV kinetic energy  
 BMAD and Xsuite codes

## Isochronous

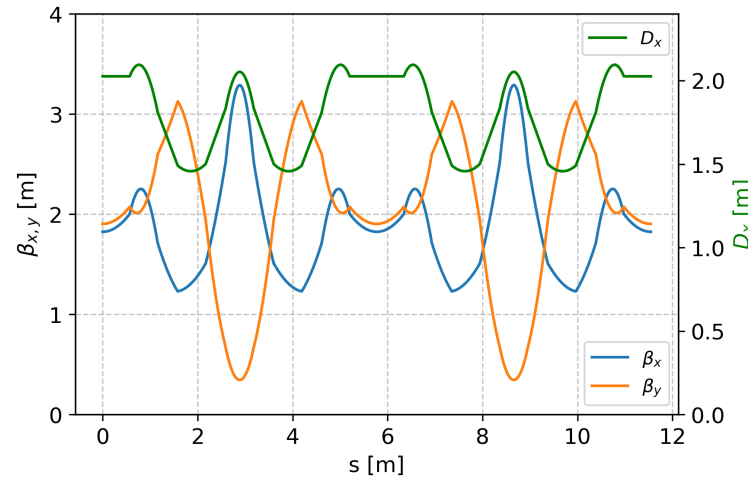

## Quasi-isochronous

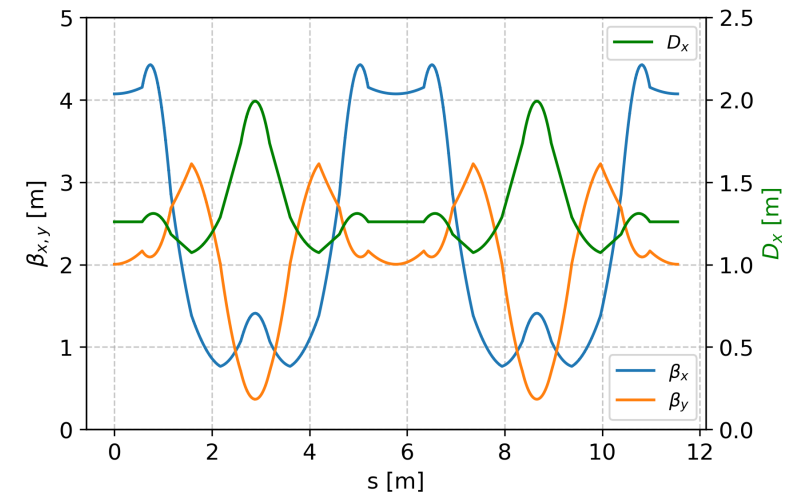

|   | Isochronous | Quasi-Isochronous |
|---|-------------|-------------------|
| Ring circumference [m]                    |             | 11.54             |
| Beam energy [MeV/u]                       |             | 10                |
| Magnetic rigidity, $B\rho$ [T·m]          |             | 2                 |
| Beam lorentz factor, $\gamma$             |             | 1.01054           |
| Transition factor, $\gamma_t$             | 1.01054     | 1.16268           |
| Max Dispersion, $D_x^{\text{max}}$ [cm/%] | 2.1         | 1.9               |
| Betatron tune, $Q_x$                      | 1.04        | 1.15              |
| Betatron tune, $Q_y$                      | 1.27        | 1.21              |
| Dipole field [T]                          |             | 2.1266            |
| Quadrupole field, QF1 [T/m]               | 2.273       | 2.331             |
| Quadrupole field, QD [T/m]                | -2.007      | -1.932            |
| Quadrupole field, QF2 [T/m]               | 3.691       | 4.740             |

# Updated ISRS optics

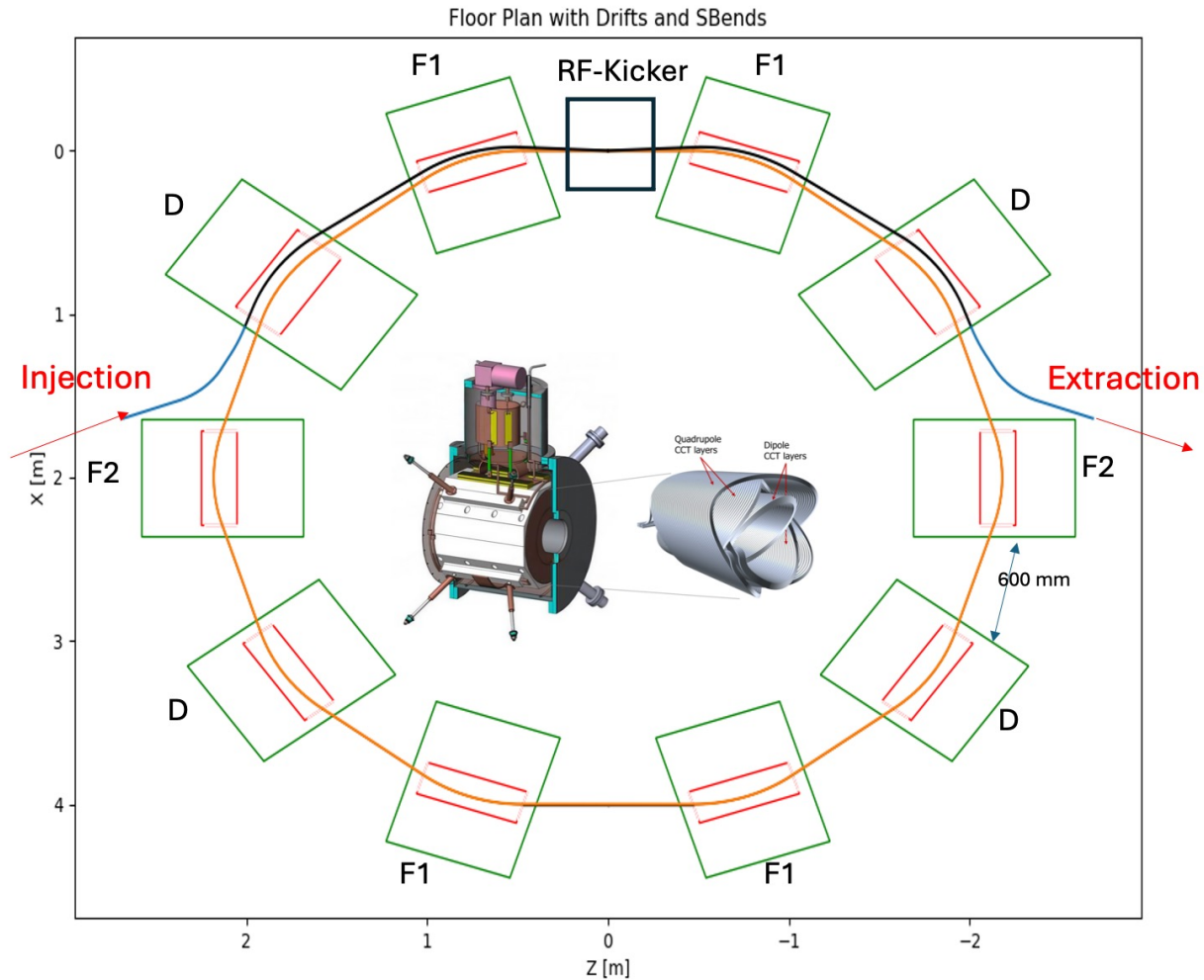

Optimisation to integrate the injection/extraction system

Drift length (to place RF-kicker)  $\approx 1$  m

Magnet separation  $\approx 0.6$  m

Mean ring diameter  $\approx 4$  m

# Updated ISRS optics

Betatron functions and first order dispersion

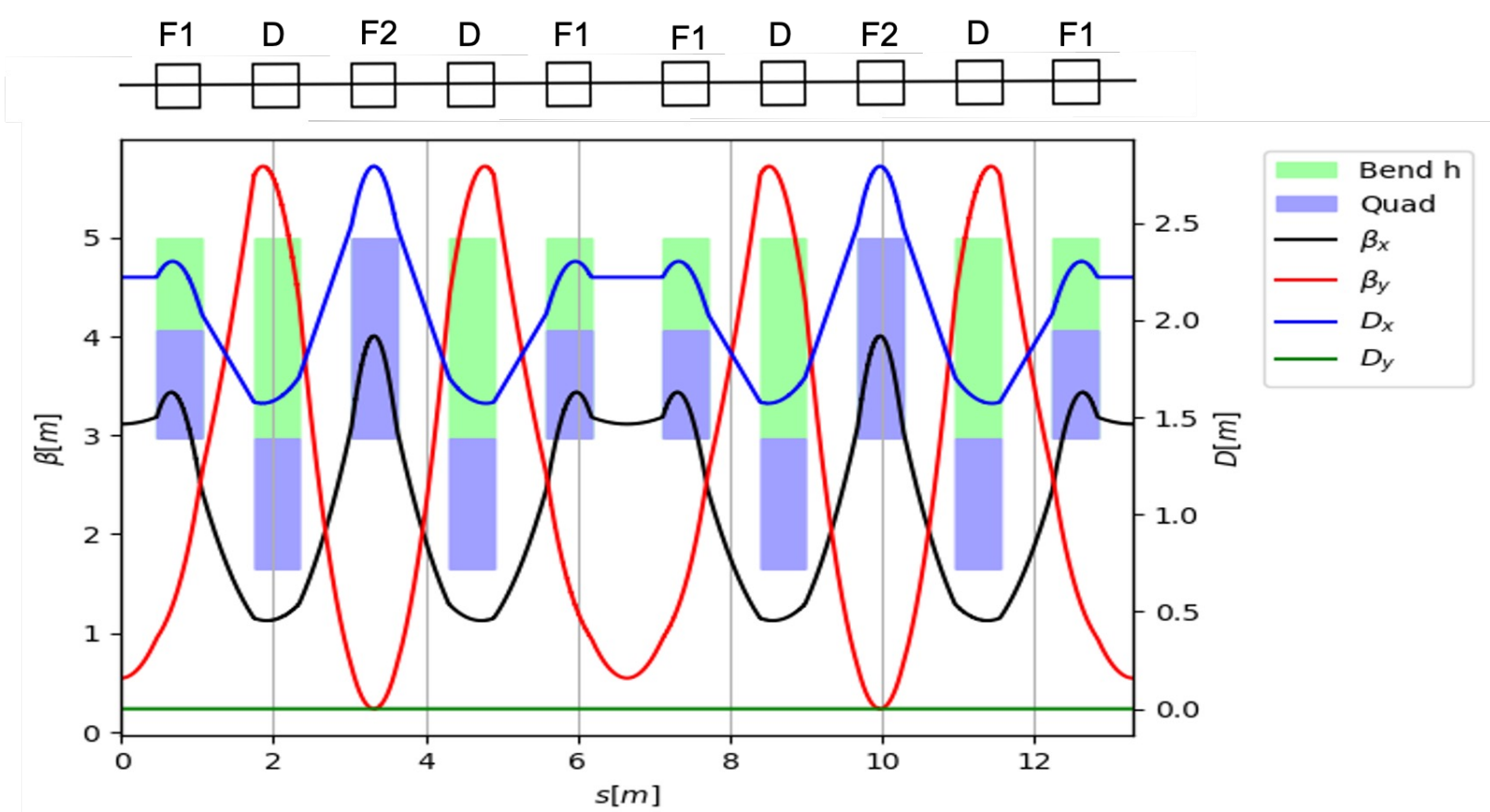

## Isochronous matching

|                           |  |
|---------------------------|--|
| CCT                       |  |
| F1                        | 1.92 T/m                                   |
| D                         | -2.33 T/m                                  |
| F2                        | 3.55 T/m                                   |
| Bending angle             | 36 degree                                  |
| Aperture radius           | 100 mm<br>150 mm (at injection/extraction) |
| Magnetic effective length | 580 mm                                     |

# Updated ISRS optics

Simulation code benchmarking and non-linear optics analysis up to 3<sup>rd</sup> order

GYCOSY

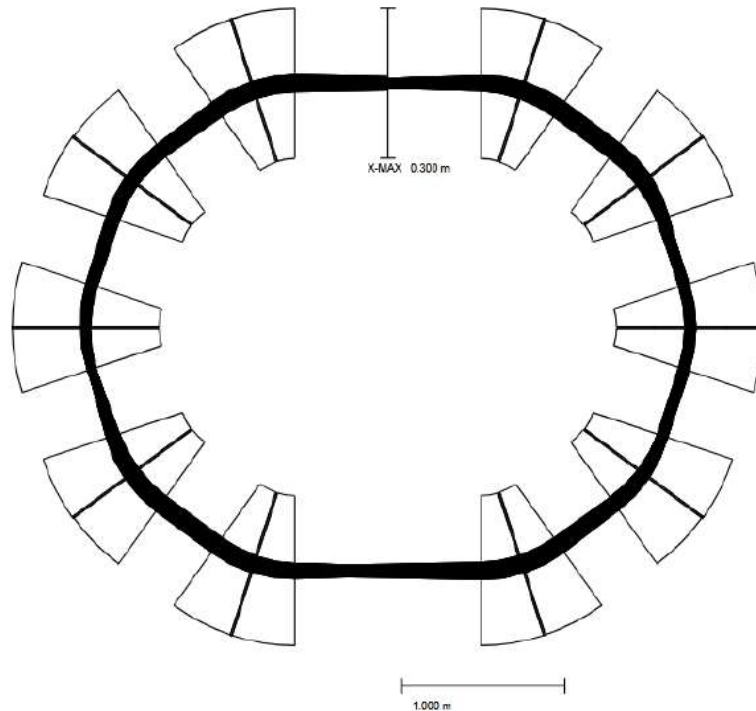

COSY INFINITY

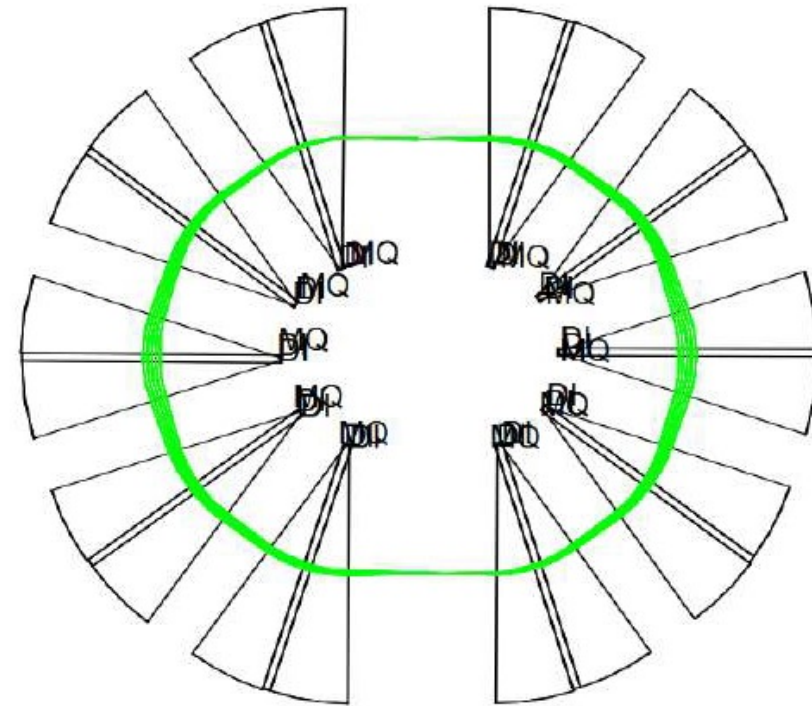

Code benchmarking has also been performed in the context of the Ion Test Bench (IONTB): T2.3 (WP2)

T. Kutukian-Nieto et al.

# Optics characterisation: Tune diagram.

## Isochronous configuration

Working point  $(Q_x, Q_y) = (1.084, 1.720)$

Resonance condition:

$$aQ_x + bQ_y = c$$

with  $a$  and  $b$  integers

and  $|a| + |b|$  the order of the resonance

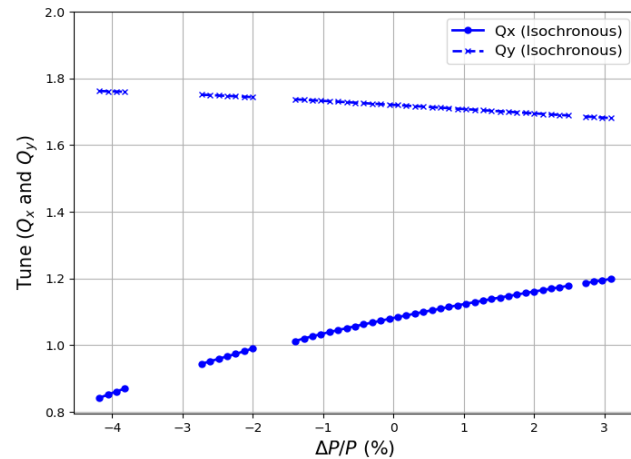

Considering potential orbit instabilities due to resonance effects, momentum acceptance  $\approx 1\%$

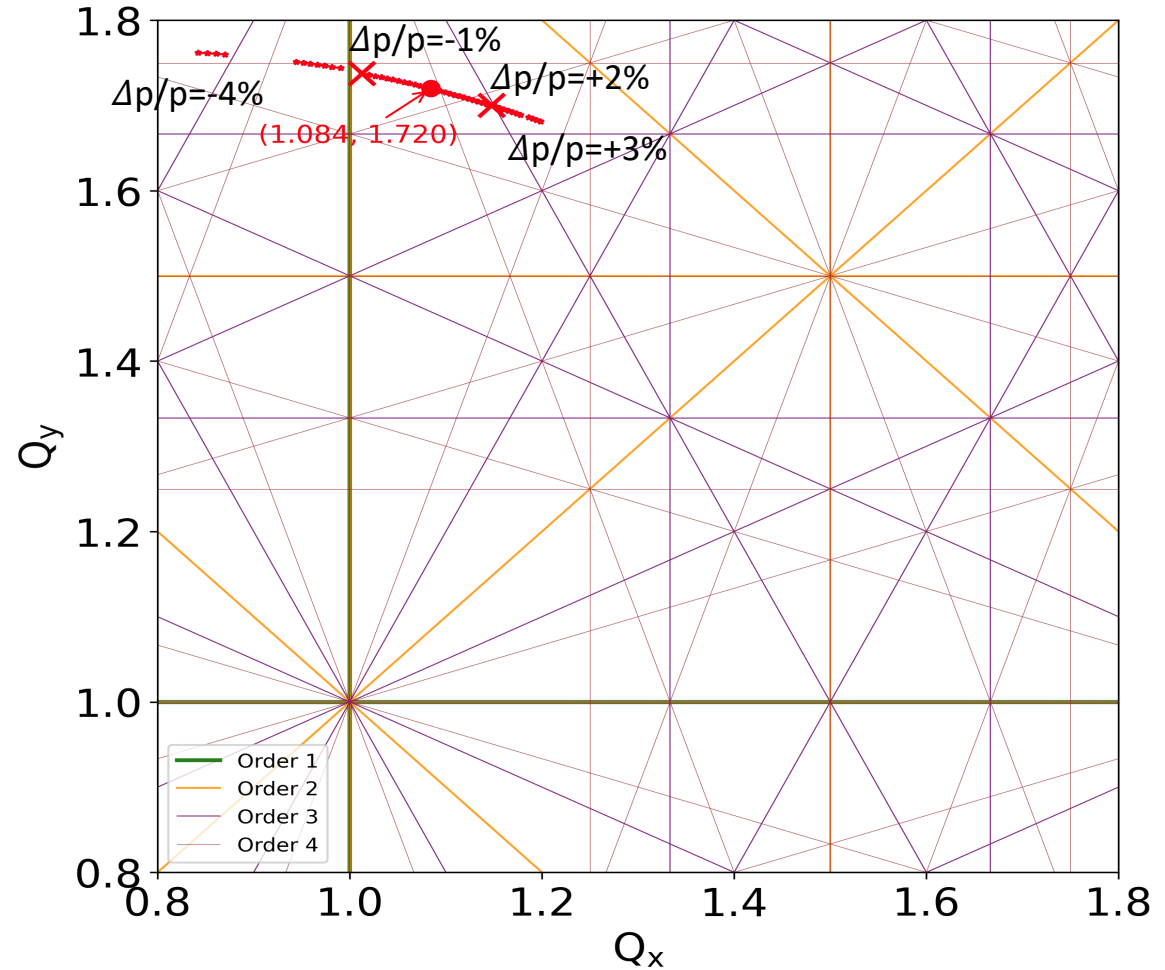

# Tracking simulations

## Isochronous configuration

1% RMS momentum spread

Different charge states

Xsuite code

$$\text{Mass resolving power } R = \frac{m}{\Delta m} = \frac{1}{\gamma_t^2} \frac{T}{\Delta T} = 2100$$

Comparison with other facilities:

VAMOS (GANIL):  $R \approx 220$

MAGNEX (INFN-LNS, Catania):  $R \approx 160$

PRISMA (LNL, Legnaro):  $R \approx 300$

S800 (NSCL / FRIB, Michigan State University):  $R \approx 2000$

FRS / Super-FRS (GSI / FAIR):  $R \sim 1000$

SHARAQ (RIKEN):  $R \sim 15000$

## Isotopes separation by ToF after 10 turns

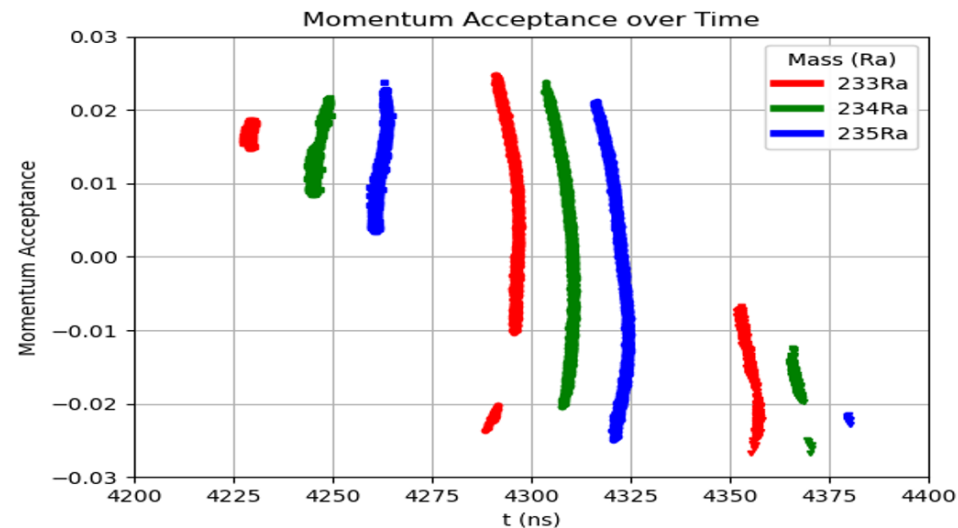
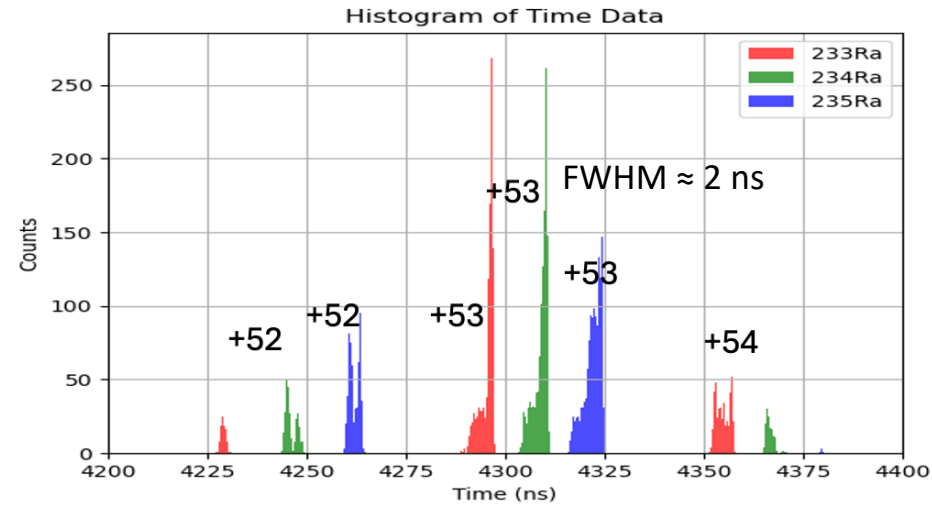

# Injection/Extraction system

## Specifications

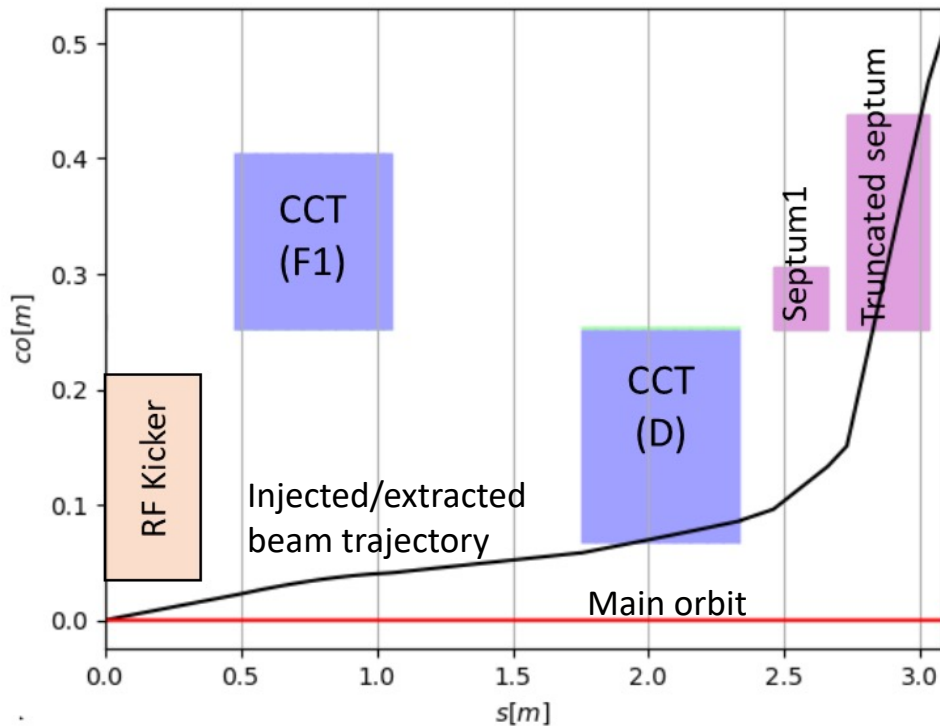

|                  | Truncated septum magnet | Standard septum magnet |
|------------------|-------------------------|------------------------|
| Bending angle    | 40 deg.                 | 10 deg.                |
| Effective length | 310 mm                  | 200 mm                 |
| Magnetic field   | 3.77 T                  | 1.70 T                 |
| Wire material    | NbTi                    | NbTi                   |
| Septum wall+coil | 20 mm                   | 3-5 mm                 |
| Aperture         | 40 mm                   | 40 mm                  |

|                  | RF Kicker   |
|------------------|-------------|
| Type             | Magnetic RF |
| Kick angle       | 45 mrad     |
| Length           | 600 mm      |
| Magnetic field   | 0.16 T      |
| Integrated field | 0.10 T      |
| Pulse length     | 350 ns      |

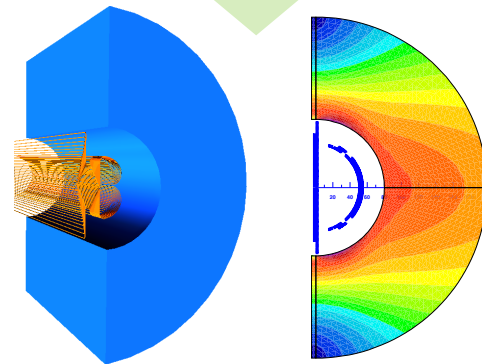

Superconducting cosine theta magnet based on the design by K. Sugita et al. (GSI), Proc. IPAC2018, WEPML036

- Magnetic-type kicker: fast pulse rise time (pulse length < revolution period in the ring (430 ns)).
- The kick angle provided is sufficient when assisted by the two CCT magnets of the ring, thus achieving a smoother beam incidence adapted to the spatial limitations between elements.

# Injection/Extraction system

## Integration

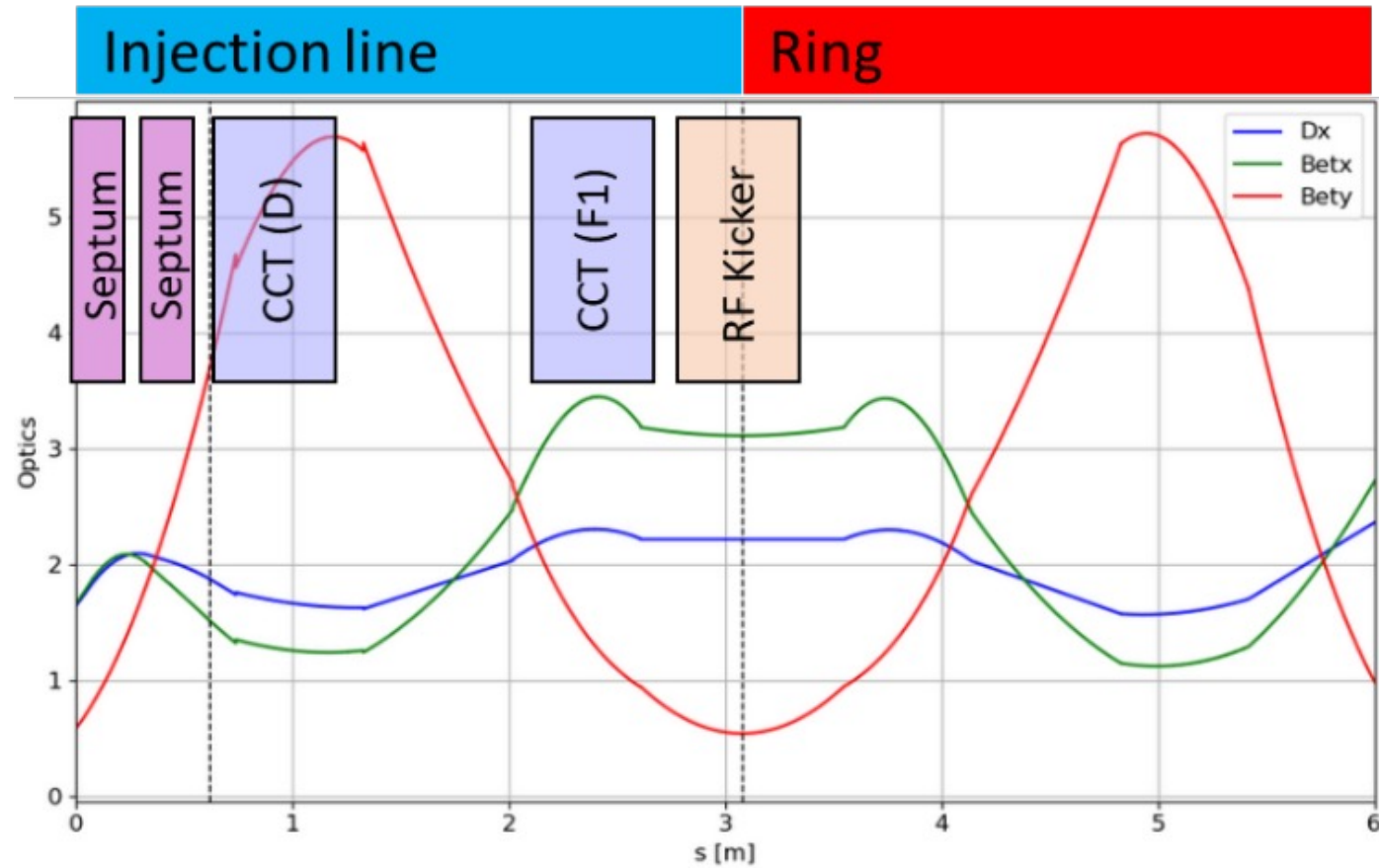

# Tracking simulations. Reaction chamber + ISRS

**MC simulation tool** (developed in collaboration with UHU)

- Cross-section calculated using the codes EMPIRE (compound reactions) and FRESKO (direct reactions)
- Energy-loss effects evaluated using the code SRIM

Phase-space distributions of reaction products for  $^{68}\text{Ni} + d$  at 10 MeV/u.

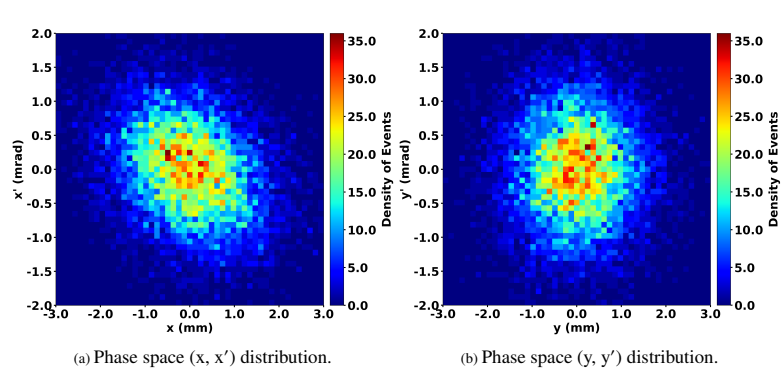

SEC chamber with  $\text{C}_2\text{D}_4$  target (98% purity)

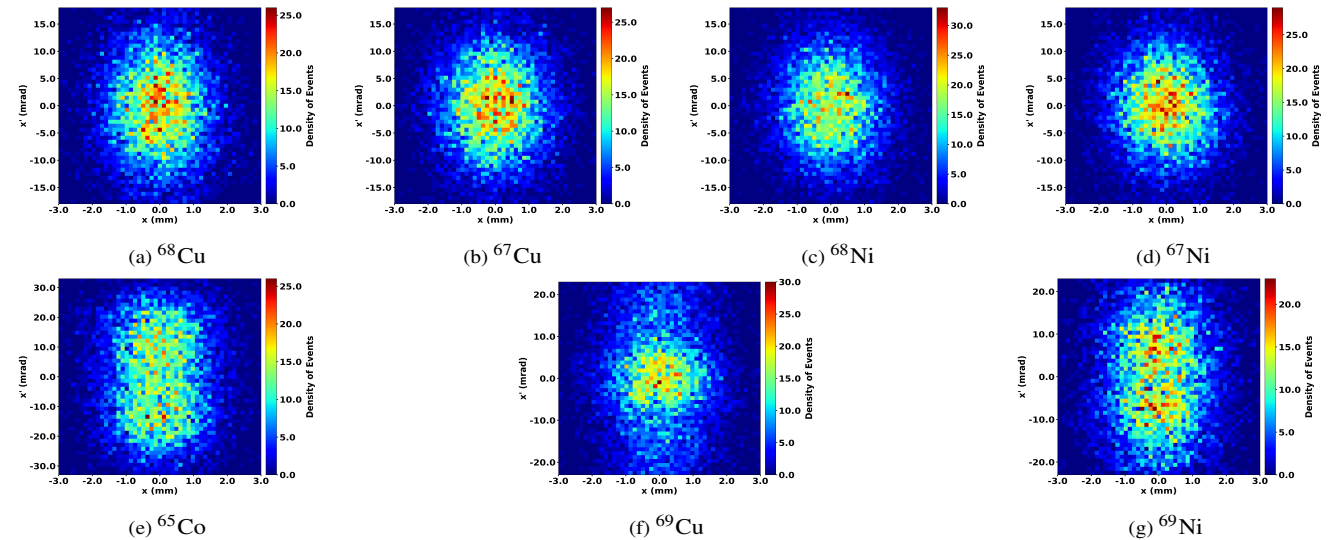

Input XT03 HIE-ISOLDE  $^{68}\text{Ni}$  beam parameters at 10 MeV/u

| Twiss parameters                              |                        |                                 |                                   |                     |
|---|------------------------|---------------------------------|-----------------------------------|---------------------|
| $(\epsilon_x, \epsilon_x)$<br>$\pi$ (mm mrad) | $(\alpha_x, \alpha_y)$ | $(\beta_x, \beta_y)$<br>(m/rad) | $(\gamma_x, \gamma_y)$<br>(rad/m) | $\Delta p/p$<br>(%) |
| (0.60, 0.60)                                  | (0.290, 0.002)         | (1.54, 1.21)                    | (0.71, 0.83)                      | 0.5                 |

For  $^{65}\text{Co}$ , the angular projection extends over a wider interval (-32 to 32 mrad), compared to the distribution from the primary  $^{68}\text{Ni}$  beam. The direct reaction products  $^{69}\text{Cu}$  and  $^{69}\text{Ni}$  exhibit angular spreads extending up to  $\pm 20$  mrad.

# Tracking simulations. Reaction chamber + ISRS

**ToF isotope separation** in ISRS after 10 turns operating in isochronous mode. RF-Track simulations

Frequency of normalised distributions in increasing order of atomic number (Z)

Case  $^{68}\text{Ni}^{16+} + \text{C}_2\text{D}_4$  target

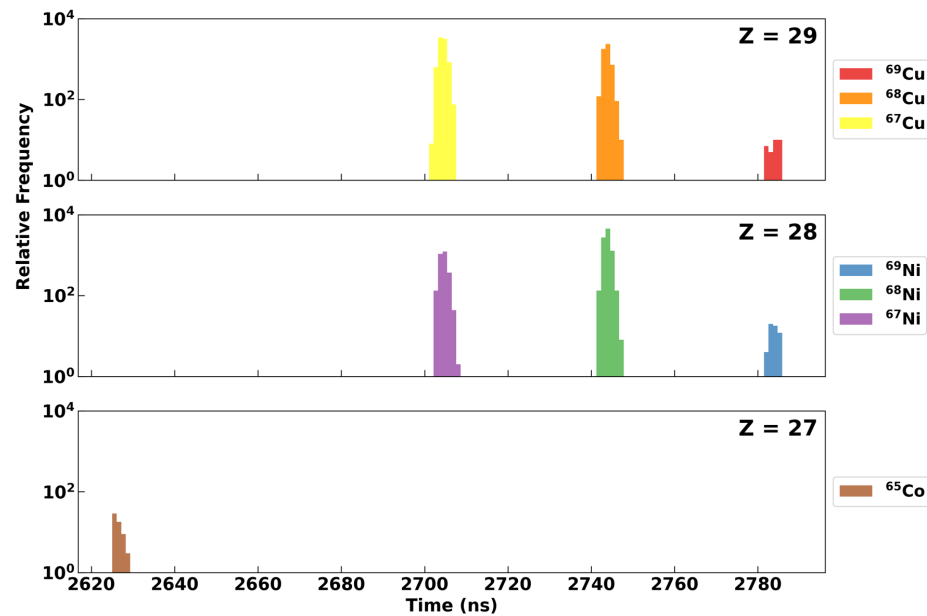

Pulse separations  $\sim 40$  ns

Case  $^{185}\text{Hg}^{44+} + \text{C}_2\text{D}_4$  target

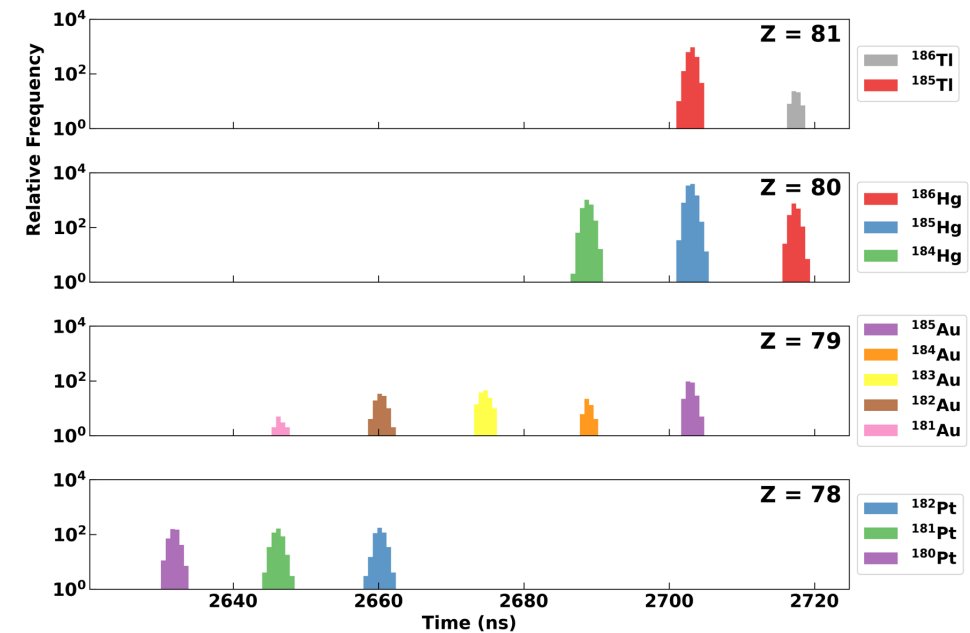

Pulse separations  $\sim 15$  ns

High sensitivity of the system, enabling separation of ions with nearly identical  $m/q$

# Summary

## WP1: 90% completed

- Frozen ISRS design.
- Full (linear and non-linear) characterisation of the ISRS optics
- Tracking simulations in isochronous and quasi-isochronous operation mode
- MC model of beam-target interaction. Integrated simulations of ToF isotope separation in ISRS considering realistic reaction cases
- Injection/Extraction: conceptual design based on truncated septum + standard septum and RF-kicker.
- Start-to-end simulation: beam-target + injection + ISRS + extraction

## Next steps:

Further optimisation of the ISRS injection/extraction system

Integration of beam diagnostics

Complete a list of error tolerances

# Thanks to all the contributors

Jorge Giner-Navarro, Fazel Taft, Yanis Fontenla (University of Valencia)

Ismael Martel et al. (University of Huelva)

Teresa Kurtukian-Nieto et al. (Instituto de Estructura de la Materia, CSIC, Madrid)

Glyn Kirby (CERN)

**Thank you for your attention!**